

HAITIAN PLASTICS MACHINERY GROUP CO., LTD
No. 1688 Haitian Road, Xiaogang, Beilun, Ningbo, P. R. China.
+ 86-574-8617 7005 (China)
+ 86-574-8617 7242 (International)
haitian@mail.haitian.com
www.haitianpm.com

NINGBO HAITIAN HUAYUAN MACHINERY CO.,LTD.
Export Processing Zone, Ningbo 315800 China
+86-574-8617 7242
+86-574-8622 1864
haitian@mail.haitian.com
www.haitianpm.com



HAITIAN **MULTI** SERIES

MA Energy-saving servo injection molding machines
Specification



HT-202300302-IV



CONTENTS

Turntable multi-color machine with wide mold platen

MA1200WM	4
MA1600WM	8
MA2000WM	12
MA2500WM	16
MA3600WM	20
MA5300WM	24

Turntable multi-color machine with narrow mold platen

MA2000M	28
---------------	----



MA / WM Series M

Turntable multi-color machine with wide mold platen
1,200-5,300 kN

MA1200WM

Turntable multi-color machine with wide mold platen

 SPECIFICATIONS
 MACHINE TYPE

		MA1200WM/160-80					MA1200WM/80-80				MA1200WM/80-50				
CLAMPING UNIT															
Clamping force	kN						1200								
Mold opening stroke	mm						310								
Dist. between tie bars (HxV)	mm						609×403								
Diameter of rotary platen	mm						Ø650								
Max. mold install diameter	mm						Ø755								
Bearing Capacity of Rotary Platen ①	t						0.5								
Mold height max.	mm						400								
Mold height min.	mm						120								
Ejector stroke ②	mm						110								
Ejector force	kN						22×2								
Nozzle center distance ③	mm						350								
Distance between molds positing centers	mm						350								
INJECTION UNIT															
		160			80		80		80		80		50		
		A	B	C	A	B	A	B	A	B	A	B	A	B	
Screw diameter	mm	26	30	34	22	26	22	26	22	26	22	26	19	22	
Screw L/D ratio	L/D	24	21	19	20	20	20	20	20	20	20	20	20	20	
Injection volume (theoretical)	cm ³	66	88	113	38	53	38	53	38	53	38	53	21	36	
Injection weight (PS)	g	60	80	103	35	48	35	48	35	48	35	48	19	33	
Injection rate (PS)	g/s	53	71	91	55	77	55	77	55	77	55	77	55	73	
Plasticizing rate (GPPS) ④	g/s	6.1	8.3	11.2	3.6	6.4	3.6	6.4	3.6	6.4	3.6	6.4	2.5	3.6	
Injection pressure	MPa	240	180	140	232	166	232	166	232	166	232	166	234	175	
Screw speed	rpm	0~240			0~300		0~300		0~300		0~300		0~300		
OTHERS															
Pump motor power	kW	13+13					13+13				13+13				
Heater power	kW	6.9			4.9		6.8		4.9		6.8		4.3		4.2
Machine dimension (LxWxH)	m	5.0×1.7×2.16					5.0×1.7×2.16				5.0×1.7×2.16				
Machine weight	t	5					4.9				4.9				
Hopper capacity	kg	25			25		25		25		25		25		
Oil tank	l	200					200				200				

NOTE:

- ① Load bearing of rotary table: it is the data when the mold thickness at the rotary table side is 1 / 2 of the maximum mold thickness.
 If the mold thickness at the rotary table side exceeds 1 / 2 of the maximum mold thickness, the data will be reduced accordingly.
- ② The ejection stroke is the data when the ejector transition rod is installed.
- ③ The nozzle center distance is the same as the mold positioning center distance at the fixed mold side.
- ④ Plasticizing capacity (GPPS): GB standard, with application of GPPS plasticizing capacity of 3-zone screws.

We reserve the right to make changes as a result of further technical advantages.

DIMENSIONS MA1200WM

Platen dimensions fixed platen

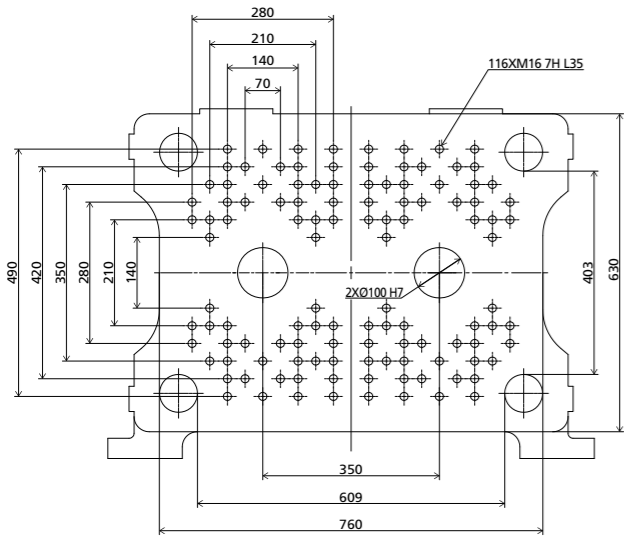

Front dimension of rotary table

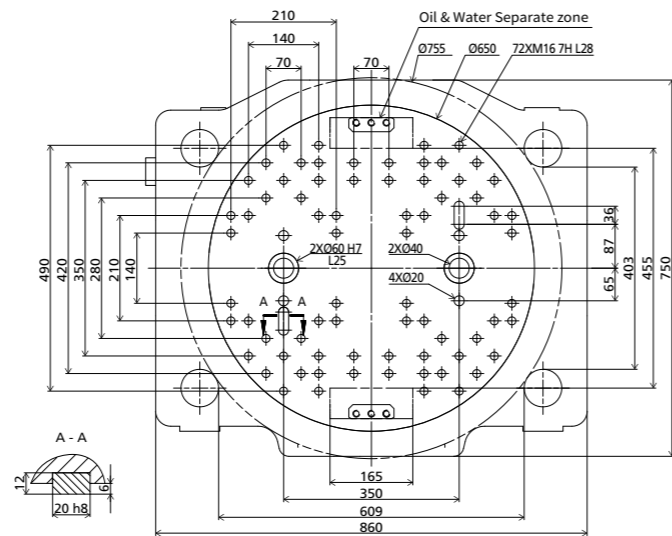

Note : M12 screw hole should be drilled on the ejector plate corresponding to the location of ejection hole, which is used to install the ejector transition rod.

Robot mechanical interface

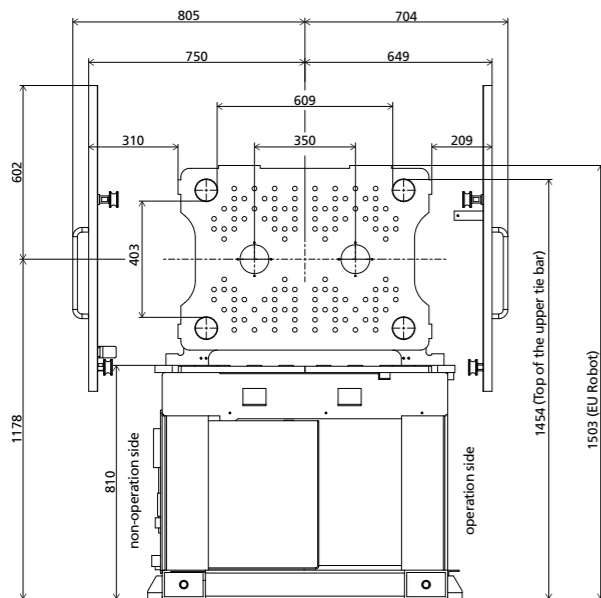

Side dimension drawing of platen

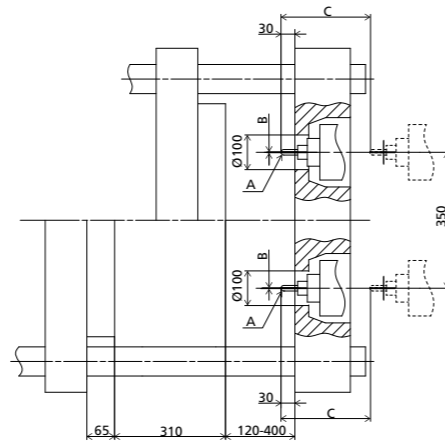

INJECTION UNIT	A	B	C
160	SR10	Ø2	270
80	SR10	Ø2	270
50	SR10	Ø2.2	270

Front view

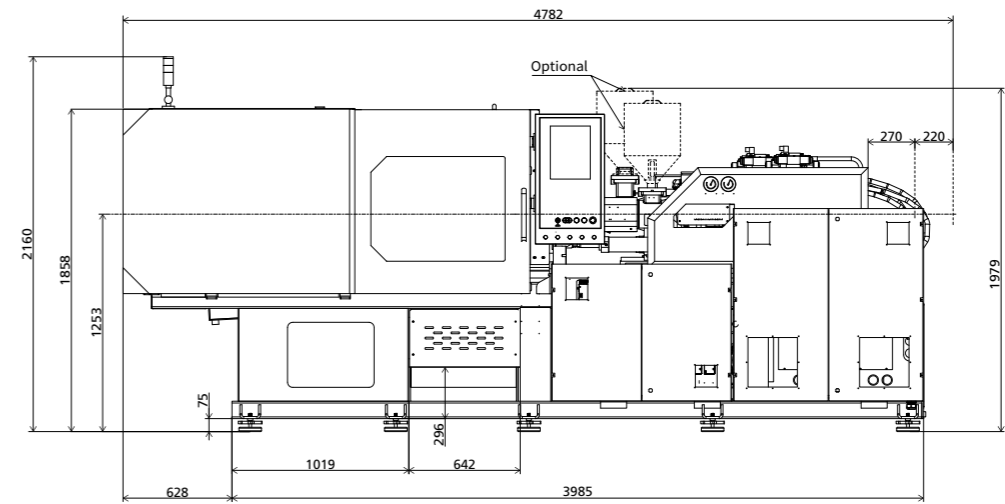

Top view

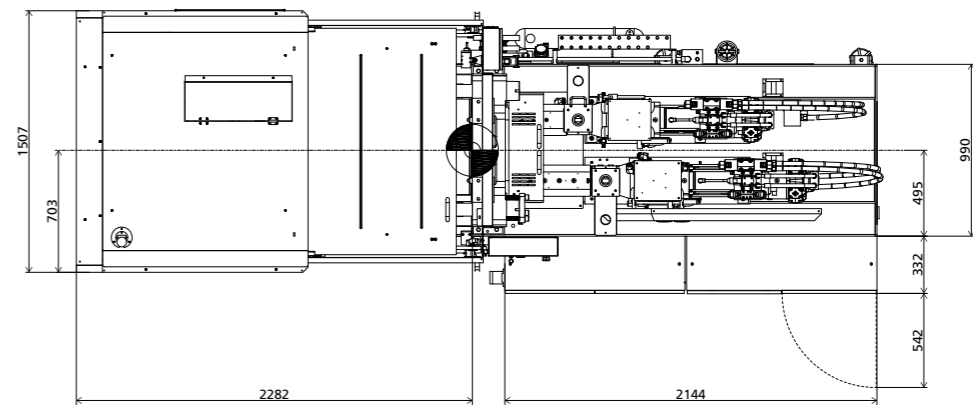

Side view

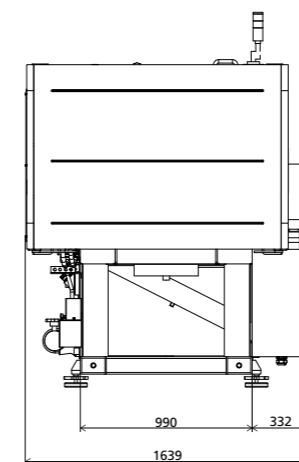

Robot top view fixed platen

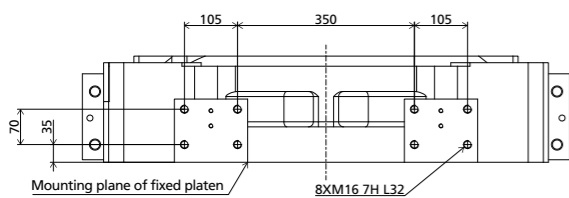

Platen dimension of hopper installation

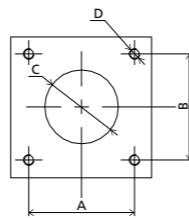

INJECTION UNIT	A	B	C	D
160	115	115	Ø70	4xM10-7H L20
80	115	115	Ø70	4xM10-7H L20
50	115	115	Ø70	4xM10-7H L20

We reserve the right to make changes as a result of further technical advantages.

MA1600WM

Turntable multi-color machine with wide mold platen

SPECIFICATIONS
MACHINE TYPE

		MA1600WM/280-160			MA1600WM/160-160			MA1600WM/160-80			MA1600WM/80-80			MA1600WM/80-50											
CLAMPING UNIT																									
Clamping force	kN													1600											
Mold opening stroke	mm													340											
Dist. between tie bars (HxV)	mm													700x420											
Diameter of rotary platen	mm													Ø730											
Max. mold install diameter	mm													Ø850											
Bearing Capacity of Rotary Platen ①	t													0.7											
Mold height max.	mm													460											
Mold height min.	mm													150											
Ejector stroke ②	mm													120											
Ejector force	kN													33x2											
Nozzle center distance ③	mm													420											
Distance between molds positing centers	mm													420											
INJECTION UNIT																									
		280			160			160			160			80		80		80		80		50			
		A	B	C	A	B	C	A	B	C	A	B	C	A	B	A	B	A	B	A	B	A	B		
Screw diameter	mm	32	36	40	26	30	34	26	30	34	26	30	34	26	30	22	26	22	26	22	26	22	26	19	22
Screw L/D ratio	L/D	22.5	20	18	24	21	19	24	21	19	24	21	19	24	21	20	20	20	20	20	20	20	20	20	20
Injection volume (theoretical)	cm ³	122	155	191	66	88	113	66	88	113	66	88	113	66	88	38	53	38	53	38	53	38	53	21	36
Injection weight (PS)	g	111	141	174	60	80	103	60	80	103	60	80	103	60	80	35	48	35	48	35	48	35	48	19	33
Injection rate (PS)	g/s	86	109	134	53	71	91	85	113	145	53	71	91	85	113	55	77	87	122	55	77	87	122	55	73
Plasticizing rate (GPPS) ④	g/s	10.1	13.3	16.1	6.1	8.3	11.2	7.3	10.0	13.4	6.1	8.3	11.2	7.3	10.0	3.6	6.4	3.6	6.4	3.6	6.4	3.6	6.4	2.5	3.6
Injection pressure	MPa	236	187	151	240	180	140	240	180	140	240	180	140	240	180	232	166	232	166	232	166	232	166	234	175
Screw speed	rpm	0~240			0~245			0~300			0~245			0~300		0~300		0~300		0~300		0~300			
OTHERS																									
Pump motor power	kW	15+13			15+13			15+13			15+13			15+13			15+13								
Heater power	kW	10.5			6.9			6.9			6.9			4.9 6.8		4.9 6.8		4.9 6.8		4.9 6.8		4.3 4.2			
Machine dimension (LxWxH)	m	5.3x1.8x2.3			5.3x1.8x2.3			5.3x1.8x2.3			5.3x1.8x2.3			5.3x1.8x2.3			5.3x1.8x2.3								
Machine weight	t	8.3			8.2			8.1			8			8											
Hopper capacity	kg	25			25			25			25			25			25								
Oil tank	l	250			250			250			250			250											

NOTE:

- ① Load bearing of rotary table: it is the data when the mold thickness at the rotary table side is 1 / 2 of the maximum mold thickness. If the mold thickness at the rotary table side exceeds 1 / 2 of the maximum mold thickness, the data will be reduced accordingly.
- ② The ejection stroke is the data when the ejector transition rod is installed.
- ③ The nozzle center distance is the same as the mold positioning center distance at the fixed mold side.
- ④ Plasticizing capacity (GPPS): GB standard, with application of GPPS plasticizing capacity of 3-zone screws.

We reserve the right to make changes as a result of further technical advantages.

DIMENSIONS MA1600WM

Platen dimensions fixed platen

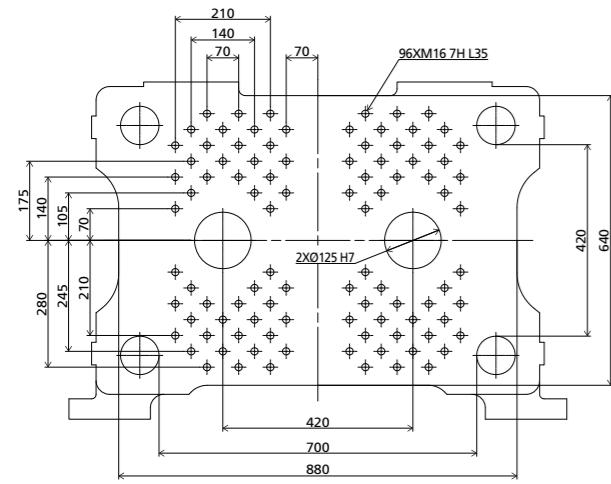

Front dimension of rotary table

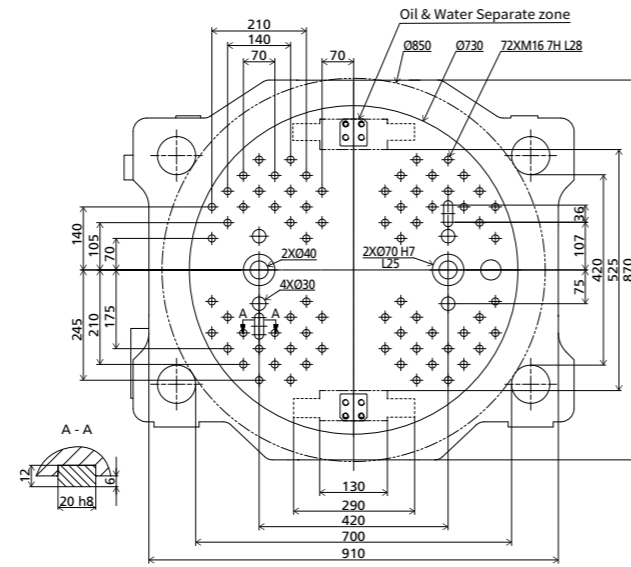

Front view

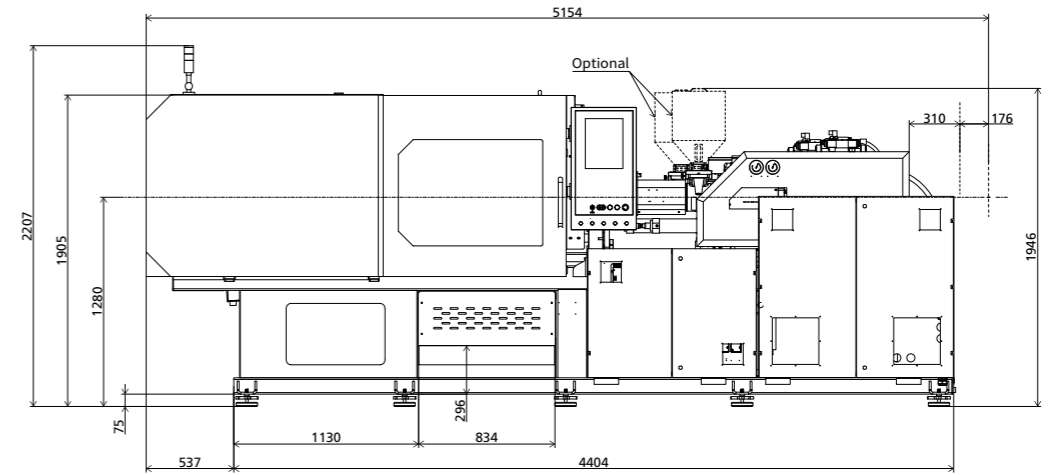

Note : M16 screw hole should be drilled on the ejector plate corresponding to the location of ejection hole, which is used to install the ejector transition rod.

Robot mechanical interface

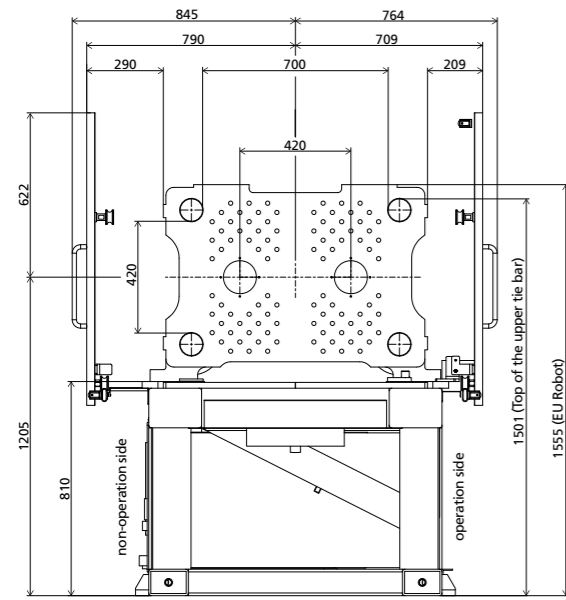

Side dimension drawing of platen

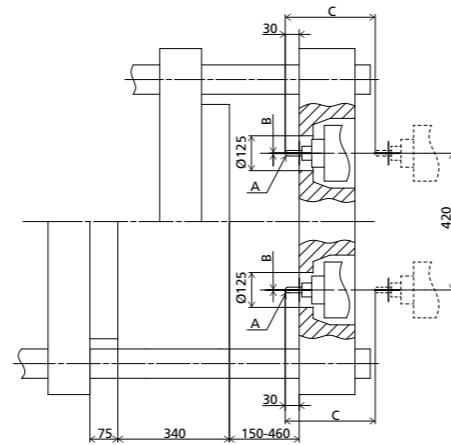

INJECTION UNIT	A	B	C
280	SR10	Ø2.5	310
160	SR10	Ø2	310
80	SR10	Ø2	310
50	SR10	Ø2.2	310

Top view

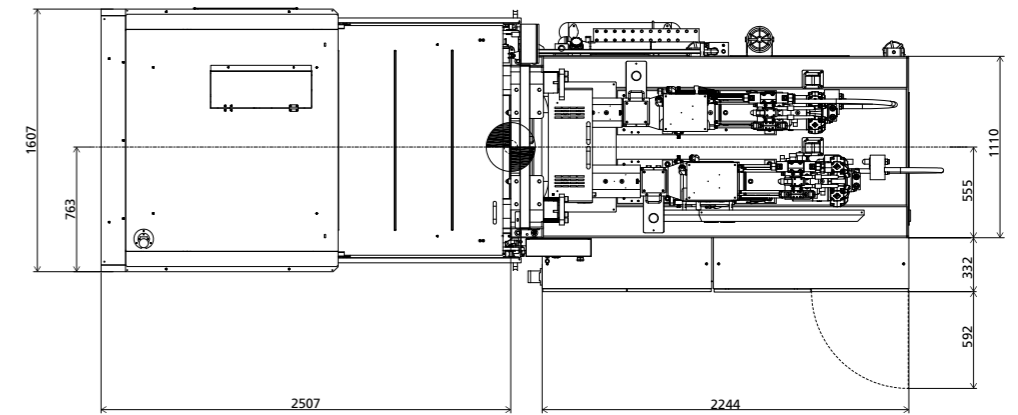

Robot top view fixed platen

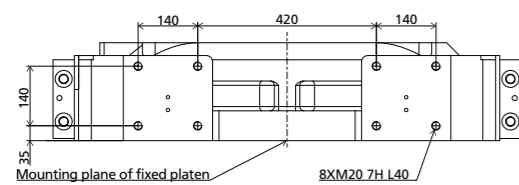

Platen dimension of hopper installation

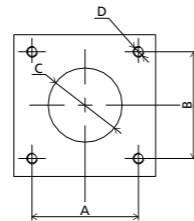

INJECTION UNIT	A	B	C	D
280	115	115	Ø70	4xM10-7H L20
160	115	115	Ø70	4xM10-7H L20
80	115	115	Ø70	4xM10-7H L20
50	115	115	Ø70	4xM10-7H L20

Side view

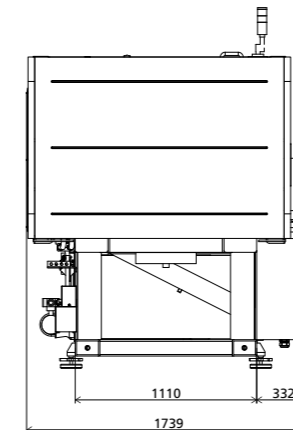

We reserve the right to make changes as a result of further technical advantages.

MA2000WM

Turntable multi-color machine with wide mold platen

SPECIFICATIONS
MACHINE TYPE

		MA2000WM/280-160			MA2000WM/160-160			MA2000WM/160-80			MA2000WM/80-80										
CLAMPING UNIT																					
Clamping force	kN										2000										
Mold opening stroke	mm										410										
Dist. between tie bars (HxV)	mm										825×505										
Diameter of rotary platen	mm										Ø870										
Max. mold install diameter	mm										Ø1000										
Bearing Capacity of Rotary Platen ①	t										1										
Mold height max.	mm										520										
Mold height min.	mm										180										
Ejector stroke ②	mm										130										
Ejector force	kN										33×2										
Nozzle center distance ③	mm										450										
Distance between molds positing centers	mm										450										
INJECTION UNIT																					
		280			160			160			160			80		80		80			
		A	B	C	A	B	C	A	B	C	A	B	C	A	B	A	B	A	B		
Screw diameter	mm	32	36	40	26	30	34	26	30	34	26	30	34	26	30	22	26	22	26	22	26
Screw L/D ratio	L/D	22.5	20	18	24	21	19	24	21	19	24	21	19	24	21	20	20	20	20	20	20
Injection volume (theoretical)	cm ³	122	155	191	66	88	113	66	88	113	66	88	113	66	88	38	53	38	53	38	53
Injection weight (PS)	g	111	141	174	60	80	103	60	80	103	60	80	103	60	80	35	48	35	48	35	48
Injection rate (PS)	g/s	86	109	134	53	71	91	85	113	145	53	71	91	85	113	55	77	87	122	55	77
Plasticizing rate (GPPS) ④	g/s	10.1	13.3	16.1	6.1	8.3	11.2	7.3	10.0	13.4	6.1	8.3	11.2	7.3	10.0	3.6	6.4	3.6	6.4	3.6	6.4
Injection pressure	MPa	236	187	151	240	180	140	240	180	140	240	180	140	240	180	232	166	232	166	232	166
Screw speed	rpm	0~240			0~245			0~300			0~245			0~300		0~300		0~300		0~300	
OTHERS																					
Pump motor power	kW	15+13			15+13			15+13			15+13			15+13		15+13		15+13		15+13	
Heater power	kW	10.5			6.9			6.9			6.9			4.9 6.8		4.9 6.8		4.9 6.8		4.9 6.8	
Machine dimension (LxWxH)	m	5.4×1.9×2.4			5.4×1.9×2.4			5.4×1.9×2.4			5.4×1.9×2.4			5.4×1.9×2.4		5.4×1.9×2.4		5.4×1.9×2.4		5.4×1.9×2.4	
Machine weight	t	9			8.9			8.9			8.8			8.7		8.7		8.7		8.7	
Hopper capacity	kg	25			25			25			25			25		25		25		25	
Oil tank	l	250			250			250			250			250		250		250		250	

NOTE:
 ① Load bearing of rotary table: it is the data when the mold thickness at the rotary table side is 1 / 2 of the maximum mold thickness. If the mold thickness at the rotary table side exceeds 1 / 2 of the maximum mold thickness, the data will be reduced accordingly.
 ② The ejection stroke is the data when the ejector transition rod is installed.
 ③ The nozzle center distance is the same as the mold positioning center distance at the fixed mold side.
 ④ Plasticizing capacity (GPPS): GB standard, with application of GPPS plasticizing capacity of 3-zone screws.

We reserve the right to make changes as a result of further technical advantages.

DIMENSIONS MA2000WM

Platen dimensions fixed platen

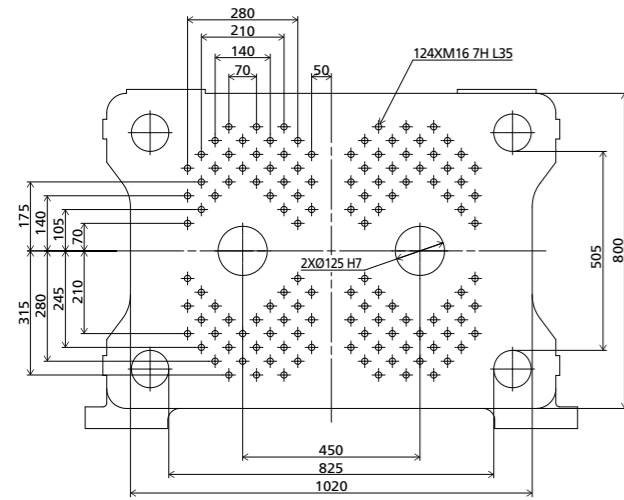

Front dimension of rotary table

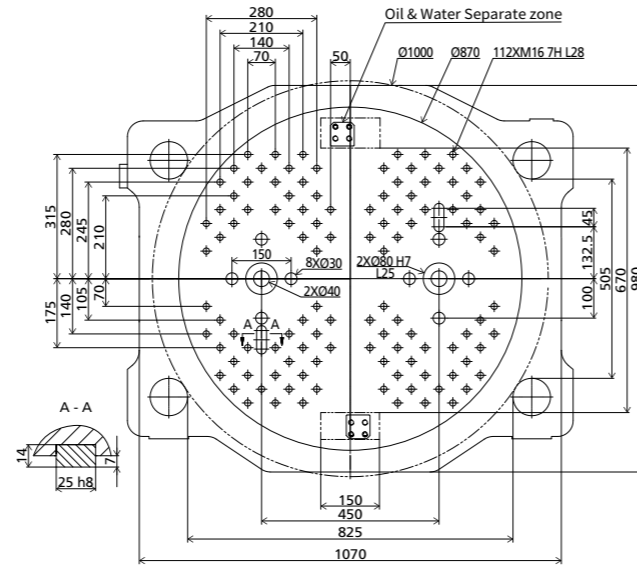

Front view

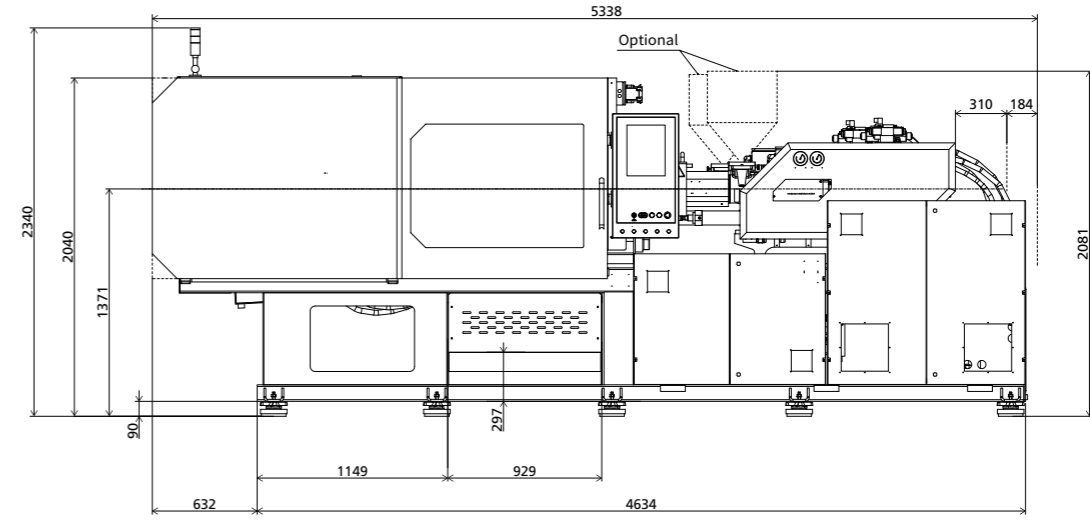

Note : M16 screw hole should be drilled on the ejector plate corresponding to the location of ejection hole, which is used to install the ejector transition rod.

Robot mechanical interface

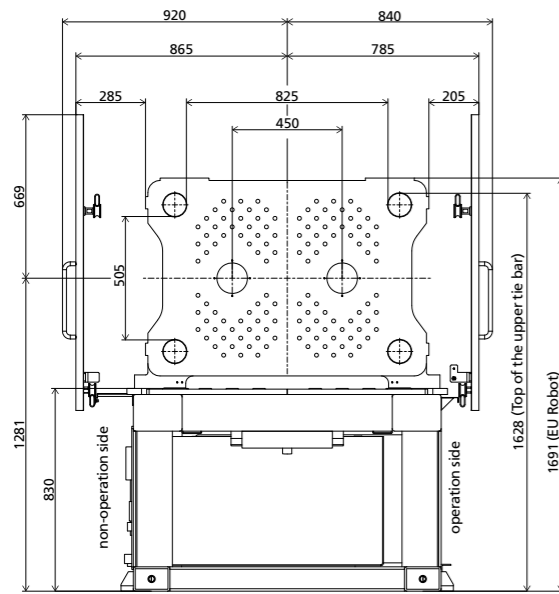

Side dimension drawing of platen

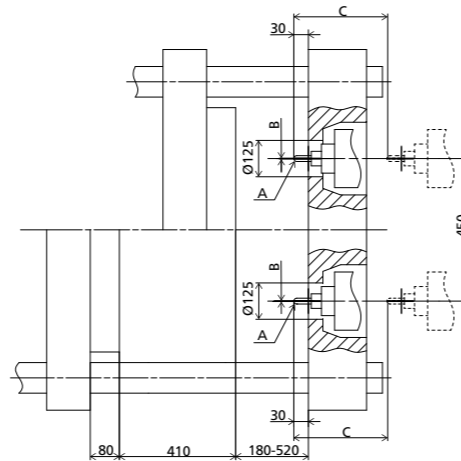

INJECTION UNIT	A	B	C
280	SR10	Ø2.5	310
160	SR10	Ø2	310
80	SR10	Ø2	310

Top view

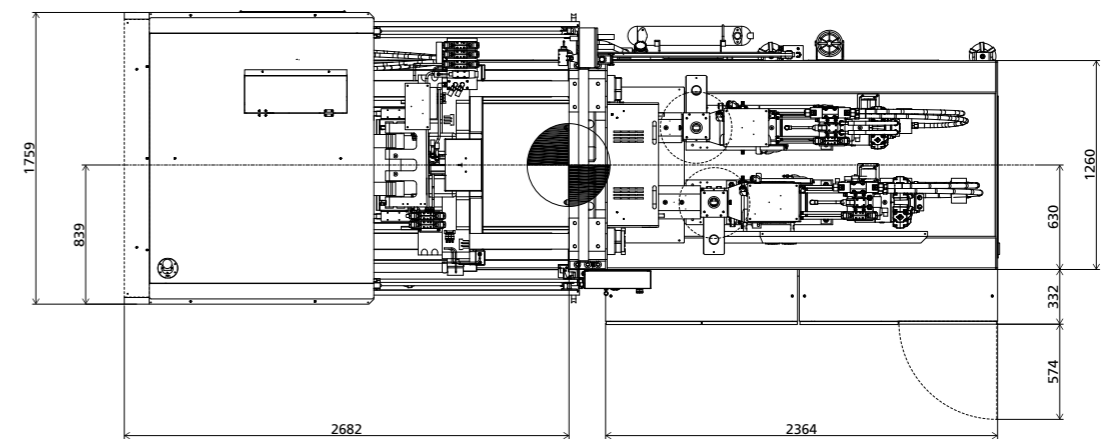

Robot top view fixed platen

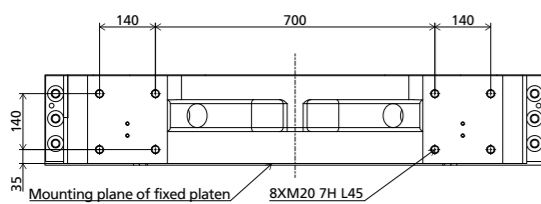

Platen dimension of hopper installation

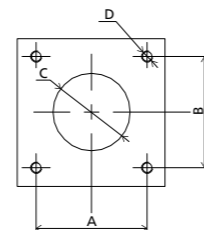

INJECTION UNIT	A	B	C	D
280	115	115	Ø70	4xM10-7H L20
160	115	115	Ø70	4xM10-7H L20
80	115	115	Ø70	4xM10-7H L20

Side view

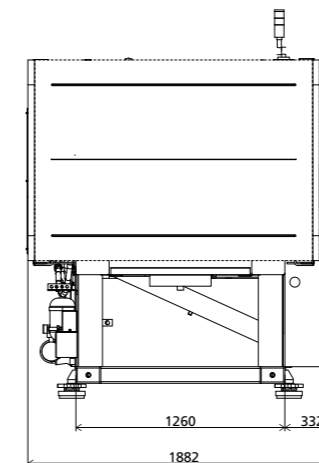

We reserve the right to make changes as a result of further technical advantages.

MA2500WM

Turntable multi-color machine with wide mold platen

SPECIFICATIONS
MACHINE TYPE

		MA2500WM/570-280						MA2500WM/380-160						MA2500WM/280-160						MA2500WM/160-80					
CLAMPING UNIT																									
Clamping force	kN	2500																							
Mold opening stroke	mm	460																							
Dist. between tie bars (HxV)	mm	910x570																							
Diameter of rotary platen	mm	Ø1000																							
Max. mold install diameter	mm	Ø1110																							
Bearing Capacity of Rotary Platen ①	t	1.5																							
Mold height max.	mm	560																							
Mold height min.	mm	200																							
Ejector stroke ②	mm	140																							
Ejector force	kN	33x2																							
Nozzle center distance ③	mm	490																							
Distance between molds positing centers	mm	490																							
INJECTION UNIT																									
		570			280			380			160			280			160			160			80		
		A	B	C	A	B	C	A	B	C	A	B	C	A	B	C	A	B	C	A	B	C	A	B	
Screw diameter	mm	40	45	50	32	36	40	36	40	45	26	30	34	32	36	40	26	30	34	26	30	34	22	26	
Screw L/D ratio	L/D	22.5	20	18	22.5	20	18	23.3	21	18.7	24	21	19	22.5	20	18	24	21	19	24	21	19	20	20	
Injection volume (theoretical)	cm ³	251	318	393	122	155	191	173	214	270	66	88	113	122	155	191	66	88	113	66	88	113	38	53	
Injection weight (PS)	g	228	289	358	111	141	174	157	195	246	60	80	103	111	141	174	60	80	103	60	80	103	35	48	
Injection rate (PS)	g/s	128	162	200	86	109	134	132	162	205	85	113	145	124	156	193	85	113	145	122	162	209	87	122	
Plasticizing rate (GPPS) ④	g/s	17.8	23.7	29.7	10.1	13.3	16.1	18.6	22.1	30.1	7.3	10.0	13.4	12.6	16.6	20.1	7.3	10.0	13.4	7.3	10.0	13.4	3.6	6.4	
Injection pressure	MPa	228	180	146	236	187	151	222	180	142	240	180	140	236	187	151	240	180	140	240	180	140	232	166	
Screw speed	rpm	0~220			0~240			0~300			0~300			0~300			0~300			0~300			0~300		
OTHERS																									
Pump motor power	kW	22+15																							
Heater power	kW	12.4			10.5			12.4			6.9			10.5			6.9			6.9			4.9 6.8		
Machine dimension (LxWxH)	m	6.3x2.1x2.6																							
Machine weight	t	13.1						13						12.9						12.8					
Hopper capacity	kg	25			25			25			25			25			25			25			25		
Oil tank	l	380																							

NOTE:

- ① Load bearing of rotary table: it is the data when the mold thickness at the rotary table side is 1 / 2 of the maximum mold thickness. If the mold thickness at the rotary table side exceeds 1 / 2 of the maximum mold thickness, the data will be reduced accordingly.
- ② The ejection stroke is the data when the ejector transition rod is installed.
- ③ The nozzle center distance is the same as the mold positioning center distance at the fixed mold side.
- ④ Plasticizing capacity (GPPS): GB standard, with application of GPPS plasticizing capacity of 3-zone screws.

We reserve the right to make changes as a result of further technical advantages.

DIMENSIONS MA2500WM

Platen dimensions fixed platen

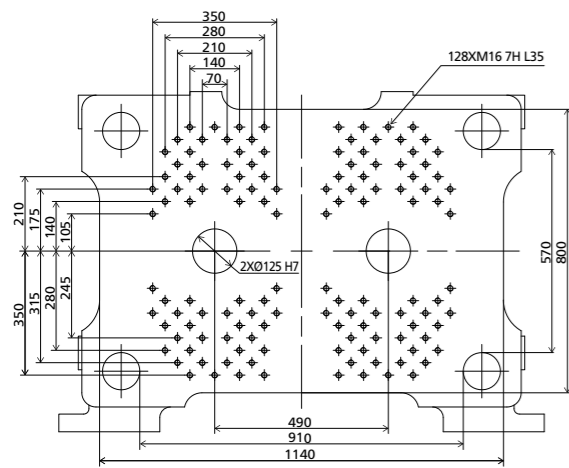

Front dimension of rotary table

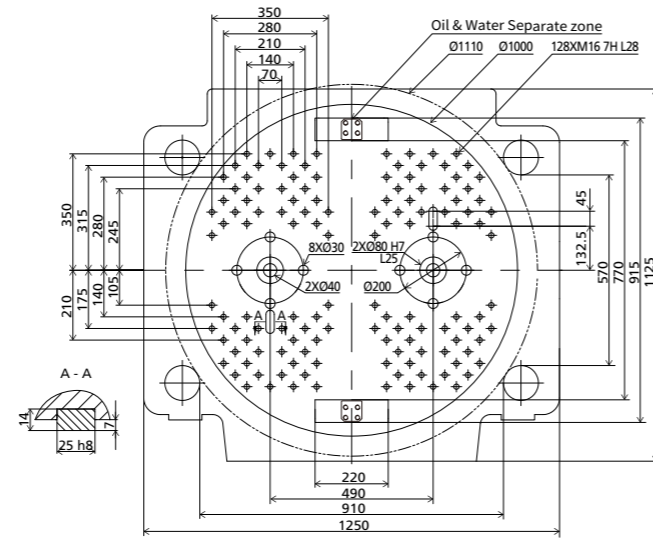

Front view

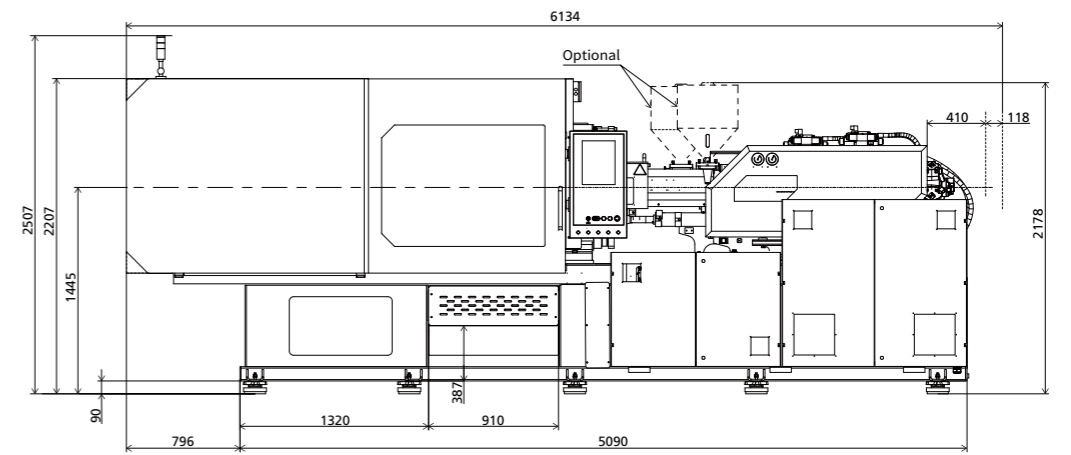

Note : M16 screw hole should be drilled on the ejector plate corresponding to the location of ejection hole, which is used to install the ejector transition rod.

Robot mechanical interface

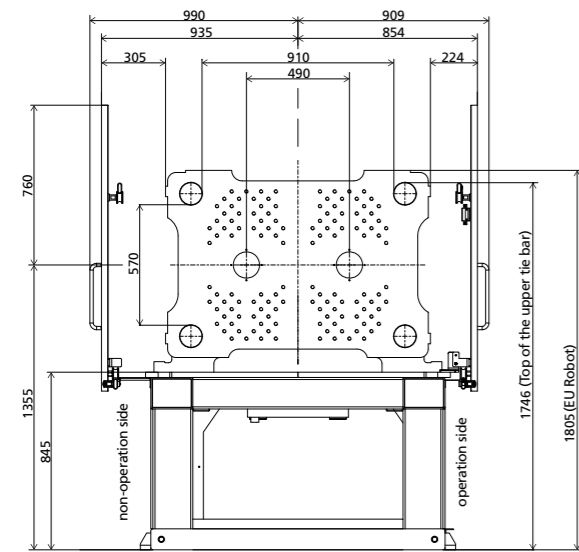

Side dimension drawing of platen

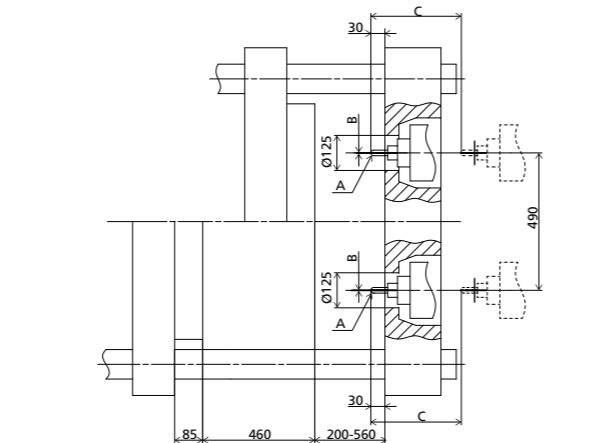

INJECTION UNIT	A	B	C
570	SR10	Ø3	410
380	SR10	Ø3	390
280	SR10	Ø2.5	390
160	SR10	Ø2	390
80	SR10	Ø2	390

Top view

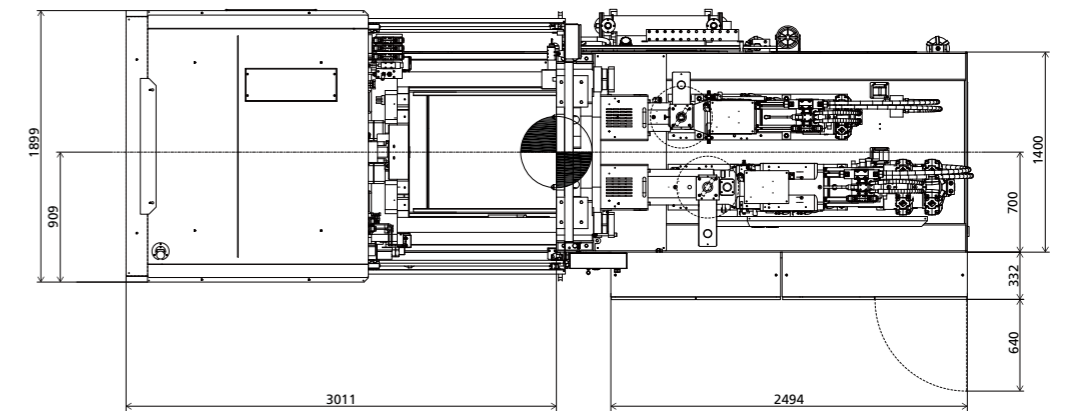

Robot top view fixed platen

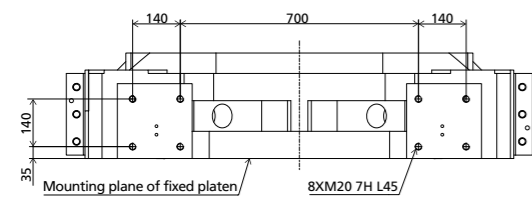

Platen dimension of hopper installation

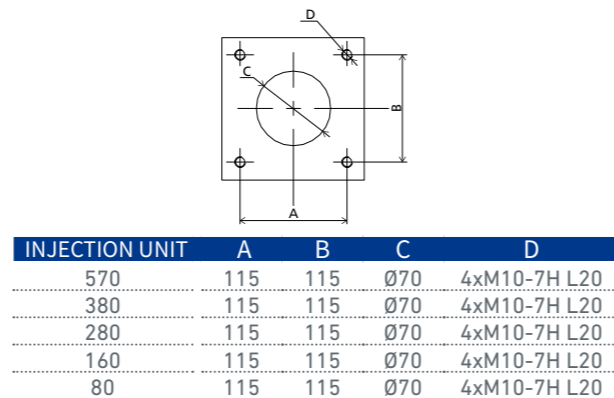

INJECTION UNIT	A	B	C	D
570	115	115	Ø70	4xM10-7H L20
380	115	115	Ø70	4xM10-7H L20
280	115	115	Ø70	4xM10-7H L20
160	115	115	Ø70	4xM10-7H L20
80	115	115	Ø70	4xM10-7H L20

Side view

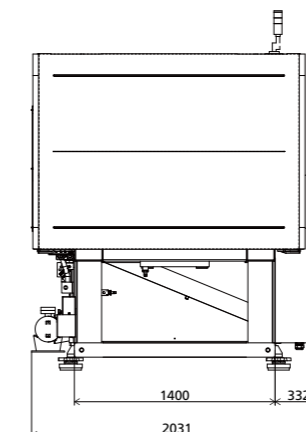

We reserve the right to make changes as a result of further technical advantages.

MA3600WM

Turntable multi-color machine with wide mold platen

SPECIFICATIONS
MACHINE TYPE

		MA3600WM/720-280						MA3600WM/570-280						MA3600WM/380-160						MA3600WM/280-160					
CLAMPING UNIT																									
Clamping force	kN	3600																							
Mold opening stroke	mm	530																							
Dist. between tie bars (HxV)	mm	1010x630																							
Diameter of rotary platen	mm	Ø1120																							
Max. mold install diameter	mm	Ø1230																							
Bearing Capacity of Rotary Platen ①	t	2.2																							
Mold height max.	mm	620																							
Mold height min.	mm	220																							
Ejector stroke ②	mm	150																							
Ejector force	kN	62x2																							
Nozzle center distance ③	mm	560																							
Distance between molds positing centers	mm	560																							
INJECTION UNIT																									
		720			280			570			280			380			160			280			160		
		A	B	C	A	B	C	A	B	C	A	B	C	A	B	C	A	B	C	A	B	C	A	B	C
Screw diameter	mm	45	50	55	32	36	40	40	45	50	32	36	40	36	40	45	26	30	34	32	36	40	26	30	34
Screw L/D ratio	L/D	22.2	20	18.2	22.5	20	18	22.5	20	18	22.5	20	18	23.3	21	18.7	24	21	19	22.5	20	18	24	21	19
Injection volume (theoretical)	cm ³	334	412	499	122	155	191	251	318	393	122	155	191	173	214	270	66	88	113	122	155	191	66	88	113
Injection weight (PS)	g	304	375	454	111	141	174	228	289	358	111	141	174	157	195	246	60	80	103	111	141	174	60	80	103
Injection rate (PS)	g/s	160	198	239	86	109	134	156	198	244	86	109	134	160	198	250	85	113	145	151	191	235	85	113	145
Plasticizing rate (GPPS) ④	g/s	21.4	27.0	33.1	10.1	13.3	16.1	21.8	29.1	36.4	10.1	13.3	16.1	18.6	22.1	30.1	7.3	10.0	13.4	12.6	16.6	20.1	7.3	10.0	13.4
Injection pressure	MPa	222	180	149	236	187	151	228	180	146	236	187	151	222	180	142	240	180	140	236	187	151	240	180	140
Screw speed	rpm	0~180			0~240			0~270			0~240			0~300			0~300			0~300			0~300		
OTHERS																									
Pump motor power	kW	30+15																							
Heater power	kW	16.3			10.5			12.4			10.5			12.4			6.9			10.5			6.9		
Machine dimension (LxWxH)	m	6.9x2.2x2.6																							
Machine weight	t	17.1			17			16.9			16.8			16.8			16.8			16.8			16.8		
Hopper capacity	kg	50			25			25			25			25			25			25			25		
Oil tank	l	450																							

NOTE:

- ① Load bearing of rotary table: it is the data when the mold thickness at the rotary table side is 1 / 2 of the maximum mold thickness. If the mold thickness at the rotary table side exceeds 1 / 2 of the maximum mold thickness, the data will be reduced accordingly.
- ② The ejection stroke is the data when the ejector transition rod is installed.
- ③ The nozzle center distance is the same as the mold positioning center distance at the fixed mold side.
- ④ Plasticizing capacity (GPPS): GB standard, with application of GPPS plasticizing capacity of 3-zone screws.

We reserve the right to make changes as a result of further technical advantages.

DIMENSIONS MA3600WM

Platen dimensions fixed platen

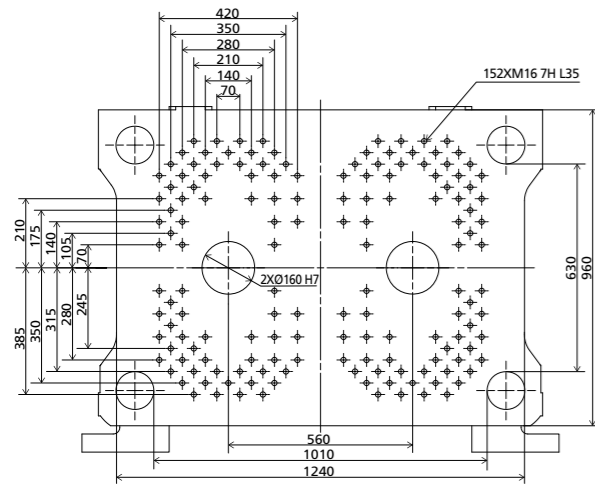

Front dimension of rotary table

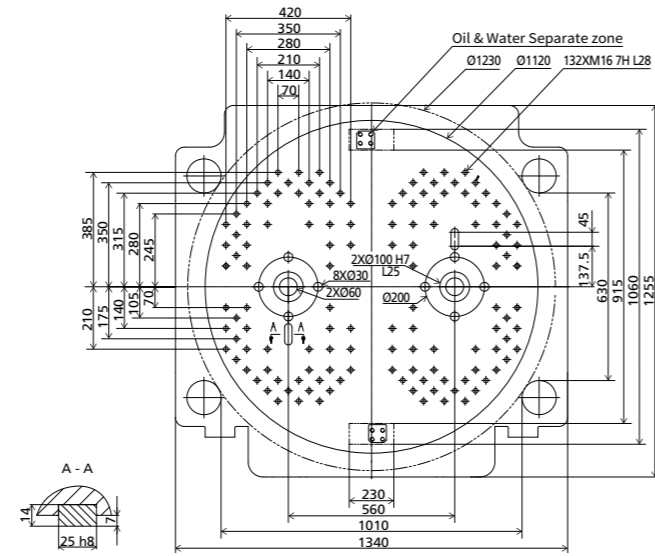

Front view

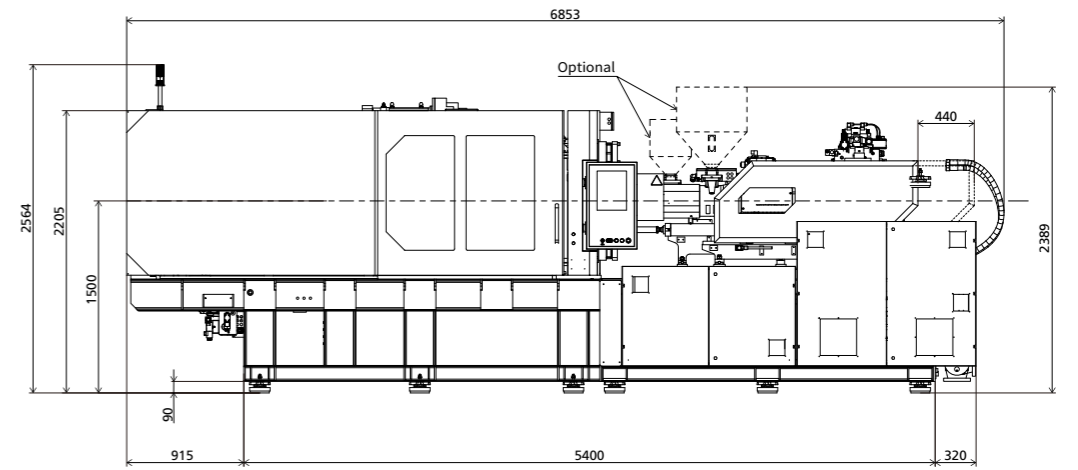

Note : M16 screw hole should be drilled on the ejector plate corresponding to the location of ejection hole, which is used to install the ejector transition rod.

Robot mechanical interface

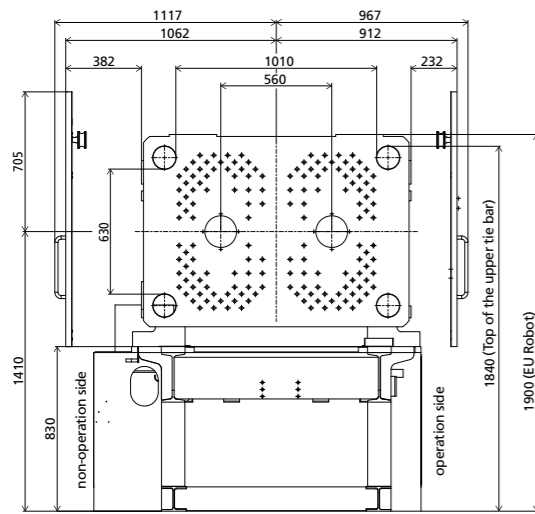

Side dimension drawing of platen

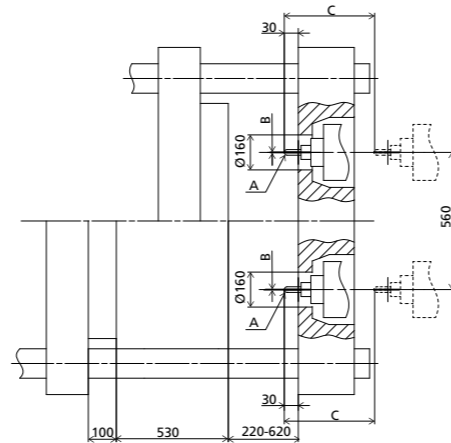

INJECTION UNIT	A	B	C
720	SR10	Ø3	440
570	SR10	Ø3	440
380	SR10	Ø3	440
280	SR10	Ø2.5	390
160	SR10	Ø2	440

Top view

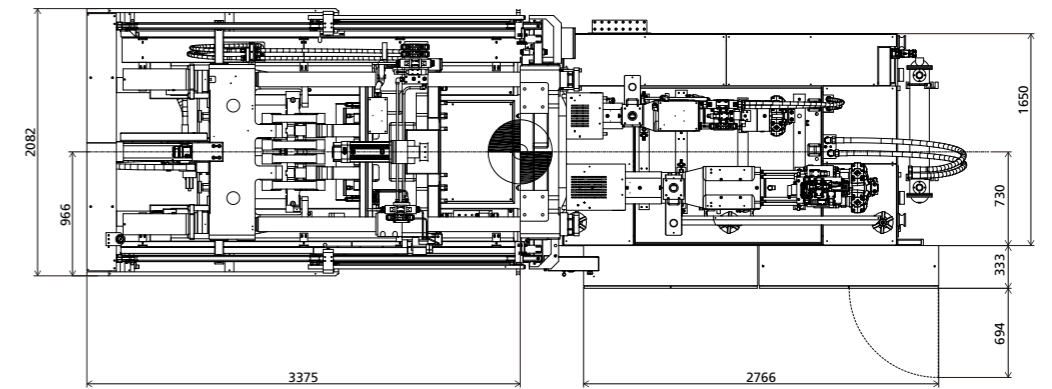

Robot top view fixed platen

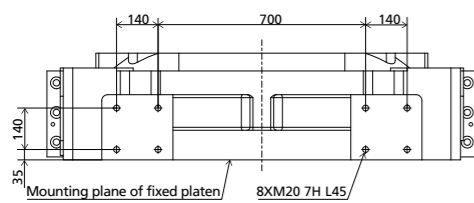

Platen dimension of hopper installation

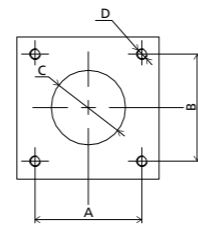

INJECTION UNIT	A	B	C	D
720	115	115	Ø70	4xM10-7H L20
570	115	115	Ø70	4xM10-7H L20
380	115	115	Ø70	4xM10-7H L20
280	115	115	Ø70	4xM10-7H L20
160	115	115	Ø70	4xM10-7H L20

Side view

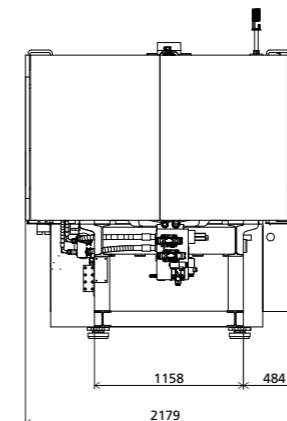

We reserve the right to make changes as a result of further technical advantages.

MA5300WM

Turntable multi-color machine with wide mold platen

SPECIFICATIONS
MACHINE TYPE

	MA5300WM/2400-380						MA5300WM/1300-380						MA5300WM/720-280						
CLAMPING UNIT																			
Clamping force	kN																		5300
Mold opening stroke	mm																		600
Dist. between tie bars (HxV)	mm																		1170×700
Diameter of rotary platen	mm																		Ø1250
Max. mold install diameter	mm																		Ø1415
Bearing Capacity of Rotary Platen ①	t																		3.3
Mold height max.	mm																		710
Mold height min.	mm																		250
Ejector stroke ②	mm																		170
Ejector force	kN																		110×2
Nozzle center distance ③	mm																		630
Distance between molds positing centers	mm																		630
INJECTION UNIT																			
	2400			380			1300			380			720			280			
	A	B	C	A	B	C	A	B	C	A	B	C	A	B	C	A	B	C	
Screw diameter	mm	65	70	75	36	40	45	55	60	65	36	40	45	45	50	55	32	36	40
Screw L/D ratio	L/D	21.5	20	18.7	23.3	21	18.7	21.8	20	18.5	23.3	21	18.7	22.2	20	18.2	22.5	20	18
Injection volume (theoretical)	cm ³	1068	1239	1423	173	214	270	618	735	863	173	214	270	334	412	499	122	155	191
Injection weight (PS)	g	972	1127	1295	157	195	246	562	669	785	157	195	246	304	375	454	111	141	174
Injection rate (PS)	g/s	277	321	369	106	131	166	296	353	414	106	131	166	286	353	427	100	126	156
Plasticizing rate (GPPS) ④	g/s	46.7	53.6	60.8	14.9	18.2	24.1	45.6	54.1	60.1	14.9	18.2	24.1	33.3	42.0	51.3	11.7	15.5	18.8
Injection pressure	MPa	229	198	172	222	180	142	214	180	153	222	180	142	222	180	149	236	187	151
Screw speed	rpm	0~184			0~240			0~255			0~240			0~280			0~280		
OTHERS																			
Pump motor power	kW	55+18.5						55+18.5						55+18.5					
Heater power	kW	32			12.4			25.5			12.4			16.3			10.5		
Machine dimension (LxWxH)	m	8.8×2.5×2.7						8.8×2.5×2.7						8.8×2.5×2.7					
Machine weight	t	30						29.5						29					
Hopper capacity	kg	50			25			50			25			50			25		
Oil tank	l	720						720						720					

NOTE:

- ① Load bearing of rotary table: it is the data when the mold thickness at the rotary table side is 1 / 2 of the maximum mold thickness. If the mold thickness at the rotary table side exceeds 1 / 2 of the maximum mold thickness, the data will be reduced accordingly.
- ② The ejection stroke is the data when the ejector transition rod is installed.
- ③ The nozzle center distance is the same as the mold positioning center distance at the fixed mold side.
- ④ Plasticizing capacity (GPPS): GB standard, with application of GPPS plasticizing capacity of 3-zone screws.

We reserve the right to make changes as a result of further technical advantages.

DIMENSIONS MA5300WM

Platen dimensions fixed platen

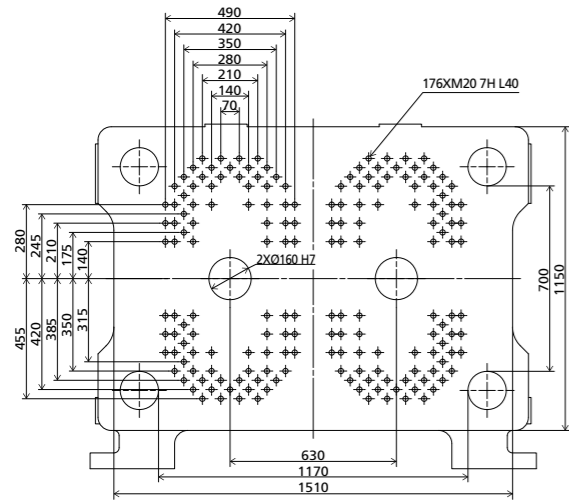

Front dimension of rotary table

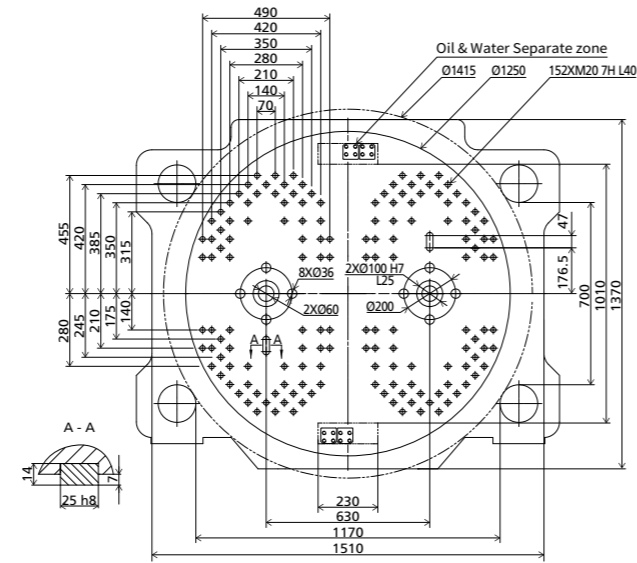

Front view

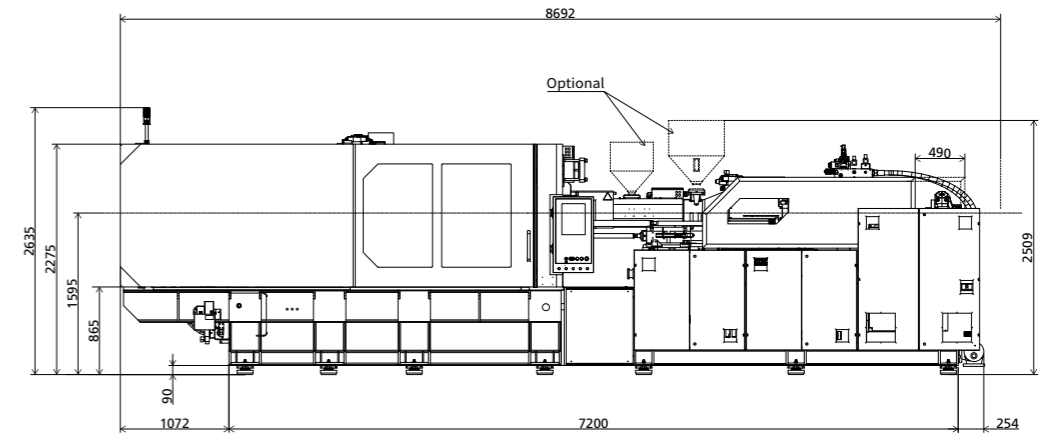

Note : M20 screw hole should be drilled on the ejector plate corresponding to the location of ejection hole, which is used to install the ejector transition rod.

Robot mechanical interface

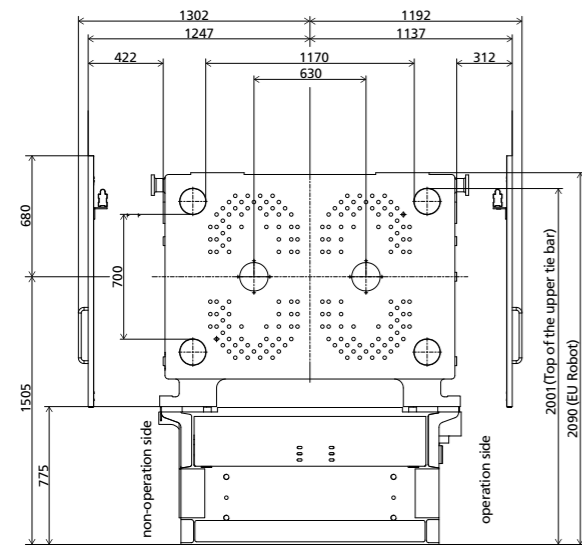

Side dimension drawing of platen

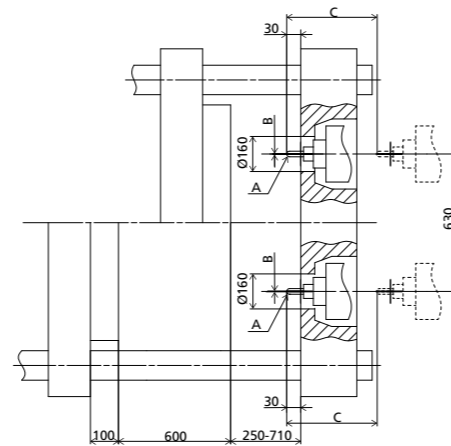

INJECTION UNIT	A	B	C
2400	SR15	Ø4	590
1300	SR10	Ø3	590
720	SR10	Ø3	490
380	SR10	Ø3	490
280	SR10	Ø2.5	490

Top view

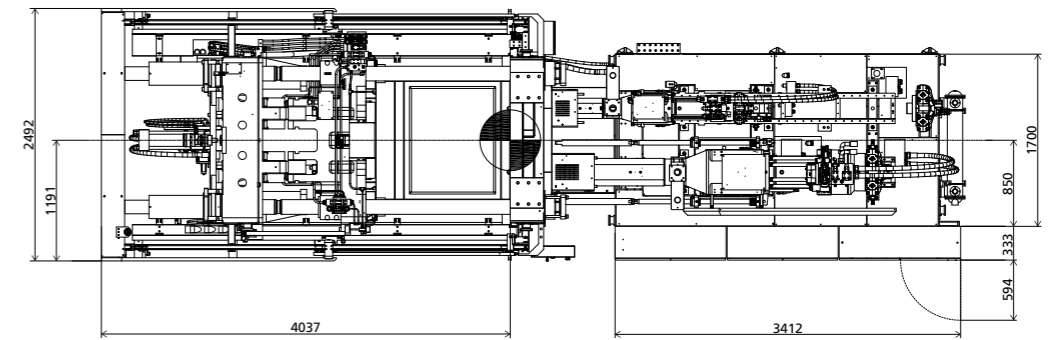

Robot top view fixed platen

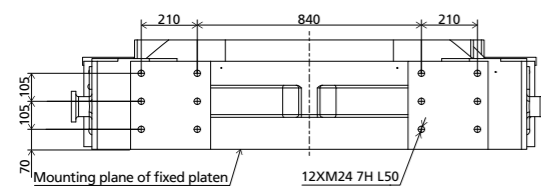

Platen dimension of hopper installation

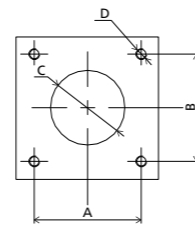

INJECTION UNIT	A	B	C	D
2400	115	115	Ø70	4xM10-7H L20
1300	115	115	Ø70	4xM10-7H L20
720	115	115	Ø70	4xM10-7H L20
380	115	115	Ø70	4xM10-7H L20
280	115	115	Ø70	4xM10-7H L20

Side view

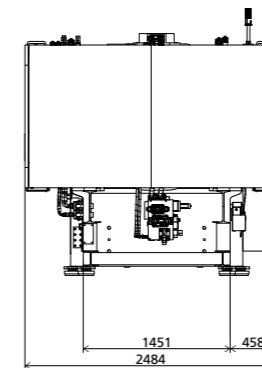

We reserve the right to make changes as a result of further technical advantages.

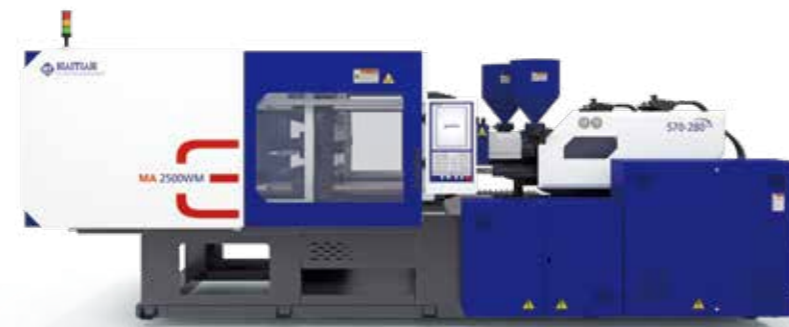

MA / M Series M

Turntable multi-color machine with narrow mold platen
1,200-5,300 kN

MA2000M

Turntable multi-color machine with narrow mold platen

SPECIFICATIONS
MACHINE TYPE

MA2000M/280-280

CLAMPING UNIT

Clamping force	kN	2000
Mold opening stroke	mm	490
Dist. between tie bars (HxV)	mm	530x530
Diameter of rotary platen	mm	Ø670
Max. mold install diameter	mm	Ø785
Bearing Capacity of Rotary Platen ①	t	0.7
Mold height max.	mm	510
Mold height min.	mm	200
Ejector stroke ②	mm	140
Ejector force	kN	28x2
Nozzle center distance ③	mm	250
Distance between molds positing centers	mm	365

INJECTION UNIT

		280			280		
		A	B	C	A	B	C
Screw diameter	mm	32	36	40	32	36	40
Screw L/D ratio	L/D	22.5	20	18	22.5	20	18
Injection volume (theoretical)	cm ³	122	155	191	122	155	191
Injection weight (PS)	g	111	141	174	111	141	174
Injection rate (PS)	g/s	86	109	134	86	109	134
Plasticizing rate (GPPS) ④	g/s	10.1	13.3	16.1	10.1	13.3	16.1
Injection pressure	MPa	236	187	151	236	187	151
Screw speed	rpm	0~250			0~250		

OTHERS

Pump motor power	kW	15+15		
Heater power	kW	10.5		10.5
Machine dimension (LxWxH)	m	5.7x2.3x1.5		
Machine weight	t	7		
Hopper capacity	kg	25		25
Oil tank	l	230		

NOTE:

- ① Load bearing of rotary table: it is the data when the mold thickness at the rotary table side is 1 / 2 of the maximum mold thickness. If the mold thickness at the rotary table side exceeds 1 / 2 of the maximum mold thickness, the data will be reduced accordingly.
- ② The ejection stroke is the data when the ejector transition rod is installed.
- ③ The nozzle center distance is the same as the mold positioning center distance at the fixed mold side.
- ④ Plasticizing capacity (GPPS): GB standard, with application of GPPS plasticizing capacity of 3-zone screws.

We reserve the right to make changes as a result of further technical advantages.

DIMENSIONS MA2000M

Platen dimensions fixed platen

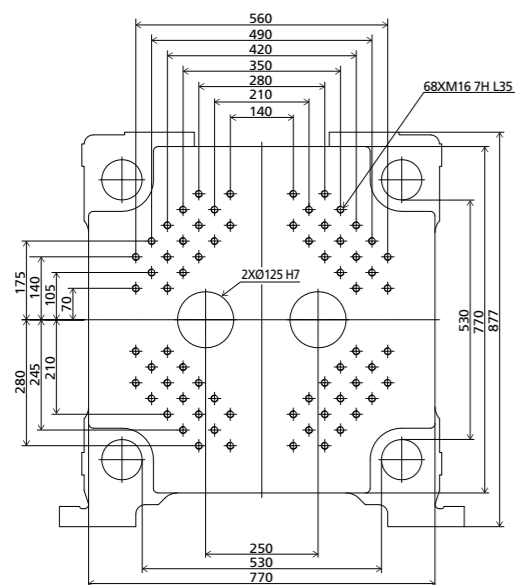

Front dimension of rotary table

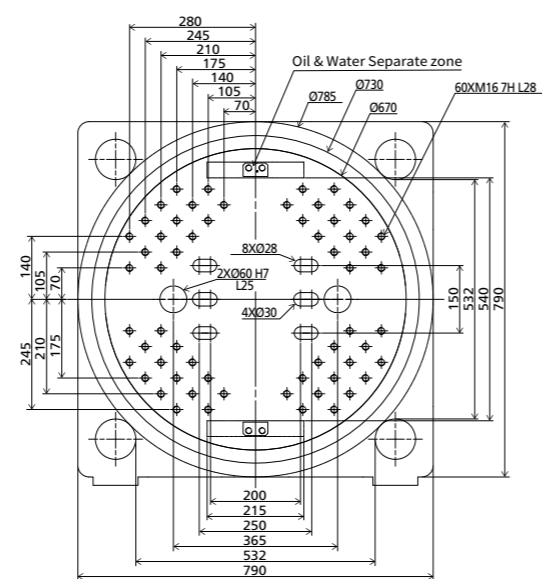

Note : M16 screw hole should be drilled on the ejector plate corresponding to the location of ejection hole, which is used to install the ejector transition rod.

Robot mechanical interface

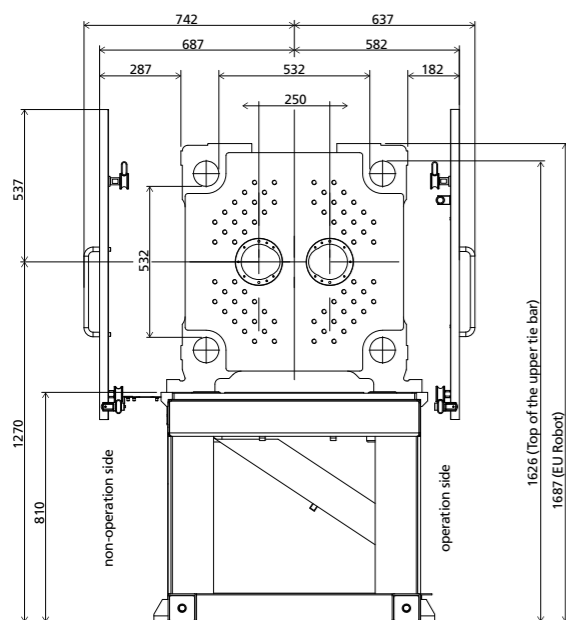

Side dimension drawing of platen

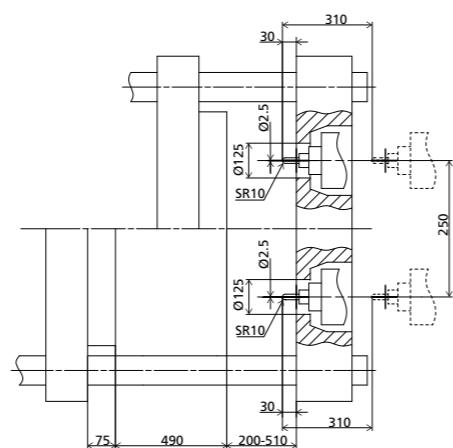

Robot top view fixed platen

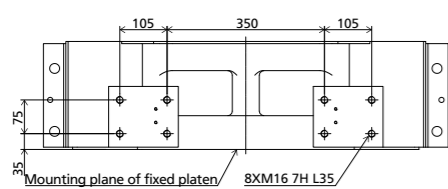

Platen dimension of hopper installation

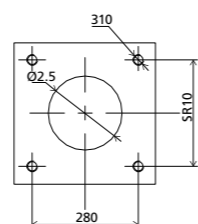

Front view

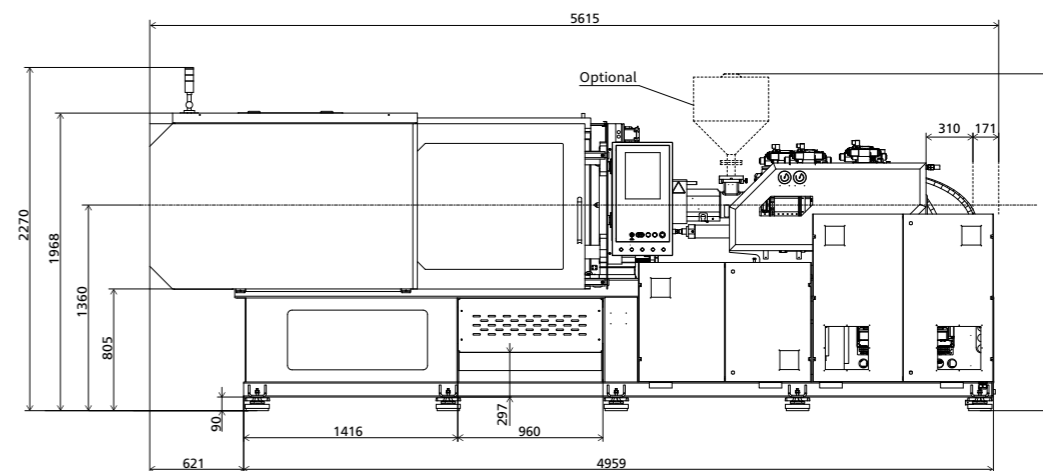

Top view

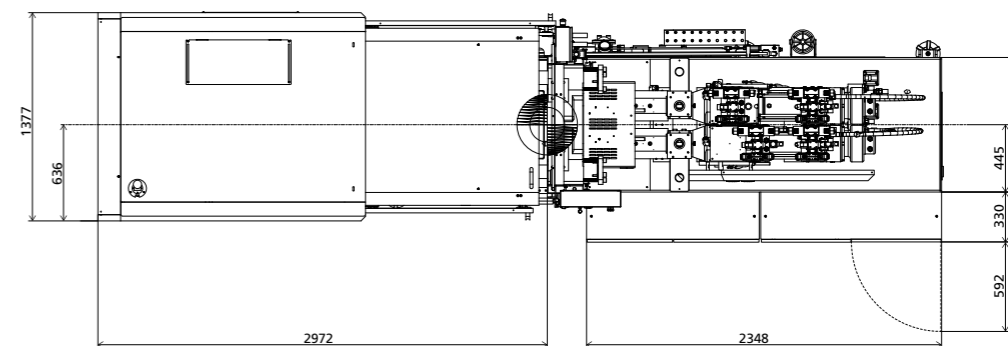

Side view

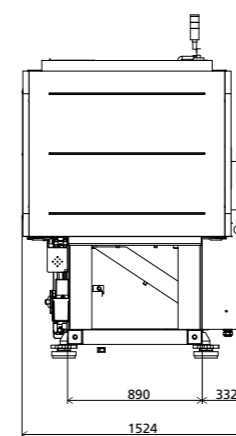

We reserve the right to make changes as a result of further technical advantages.