

TECHNOLOGY TO THE POINT



HAITIAN PLASTICS MACHINERY GROUP CO., LTD.
No.1688, Haitian Road, Xiaogang, Beilun, Ningbo, Zhejiang, China 315801
+ 86-574-8617 7005 (China)
+ 86-574-8617 7242 (International)
haitian@mail.haitian.com
www.haitianpm.com

NINGBO HAITIAN HUAYUAN MACHINERY CO.,LTD.
No.1, Nanhuan Road, Export Processing Zone, Beilun, Ningbo, Zhejiang, China 315806
+86-574-8617 7242
+86-574-8622 1864
haitian@mail.haitian.com
www.haitianpm.com



JUPITER SERIES

SERVO HYDRAULIC TWO-PLATEN SOLUTION
TECHNICAL SPECIFICATION
13,000 - 88,000 kN



JU13000 V

MACHINE TYPE		JU13000 V															
CLAMPING UNIT	Clamping force	kN	13000														
	Mold opening stroke ①	mm	2250/1500														
	Mold height min.	mm	600														
	Mold height max.	mm	1350														
	Total daylight max.	mm	2850														
	Dist. between tie-bars (H×V)	mm	1420×1170														
	Ejector stroke	mm	350														
	Ejector force	kN	230														
	Mold weight max. ②	t	23														
INJECTION UNIT			6750			8950			11500				17500				
			A	B	C	A	B	C	A	B	C	D	A	B	C		
	Screw diameter	mm	90	100	110	100	110	120	110	120	130	140	130	140	150		
	Screw L/D ratio	L/D	24.4	22	20	24.2	22	20.2	26.2	24	22.2	20.6	24	22.3	20.8		
	Injection volume (theoretical)	cm ³	2990	3691	4466	4005	4846	5767	5226	6220	7300	8466	8362	9698	11133		
	Injection weight (PS)	g	2720	3359	4064	3645	4410	5248	4756	5660	6643	7704	7609	8825	10131		
	Injection rate (PS) ③	g/s	809	999	1209	797	965	1148	884	1052	1235	1432	1281	1486	1705		
	Injection pressure	MPa	193	156	129	196	162	136	189	159	135	117	185	160	139		
	Injection pressure (max)	MPa	222	180	148	223	184	154	217	183	156	134	210	181	158		
	Plasticizing rate (GPPS) ④	g/s	103.4	127.1	150.2	120.7	144.8	167.8	123.0	142.0	164.0	187.0	168.0	192.0	220.0		
Plasticizing rate (HDPE) ⑤	g/s	155.6	191.0	227.5	181.2	217.2	247.0	187.0	217.0	240.0	273.0	252.0	283.0	336.0			
Screw speed	rpm	170			155			105				102					
OTHERS	Pump motor power	kW	127			127			135				195				
	Heater power	kW	71			83			104				123				
	Machine dimension (L×W×H) ⑥	m	9.99×3.45×3.02			10.48×3.45×3.03			10.79×3.45×3.04				11.97×3.55×4.34				
	Machine weight	t	53			54			57				62				
	Hopper capacity (OP)	kg	100			200			400				400				
	Oil tank ⑦	l	590			840			840				1670				

NOTE:

- ① With min. mold height / with max. mold height.
 ② Moving platen: 2/3 of max. mold weight.
 ③ The injection rate refers to the parameter in the differential injection condition.
 ④ Plasticizing capacity (GPPS): GB standard, with application of GPPS plasticizing capacity of 3-zone screws.
 ⑤ Plasticizing capacity (HDPE): Euromap 19, with application of HDPE plasticizing capacity of barrier screws.
 ⑥ The size is the net size of the machine, excluding the width of the feeding platform and the working platform.
 ⑦ The oil tank volume refers to the volume of the oil tank itself, excluding the volume in cylinder and pipeline. In this sense, the customer is advised to prepare the hydraulic oil according to 1.35 times of the oil tank volume.

The above plasticizing capacity is for reference only.

We reserve the right to make changes as a result of further technical advantages.

DIMENSIONS JU13000 V

CLAMPING UNIT

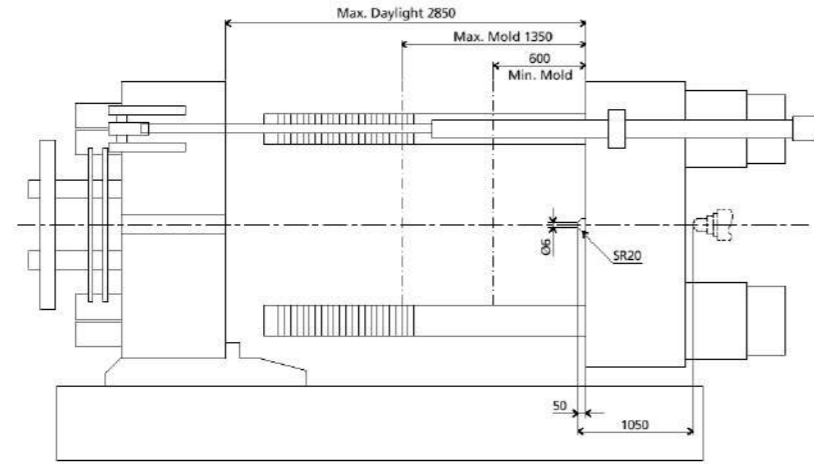

FRONT VIEW

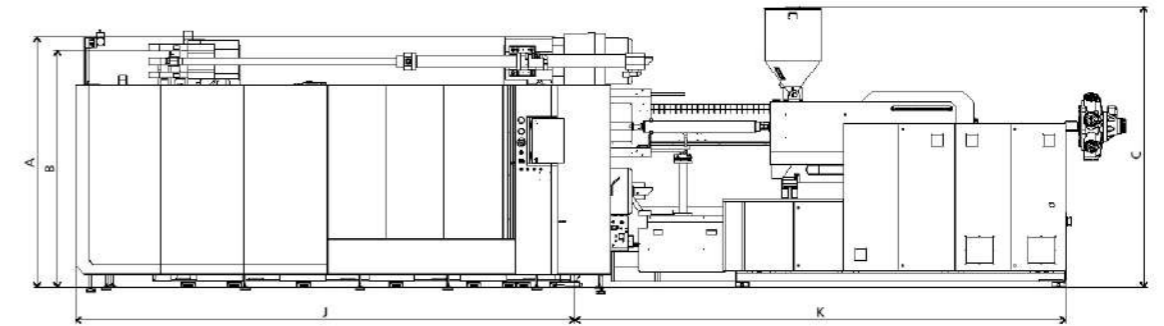

FIXED PLATEN DIMENSIONS

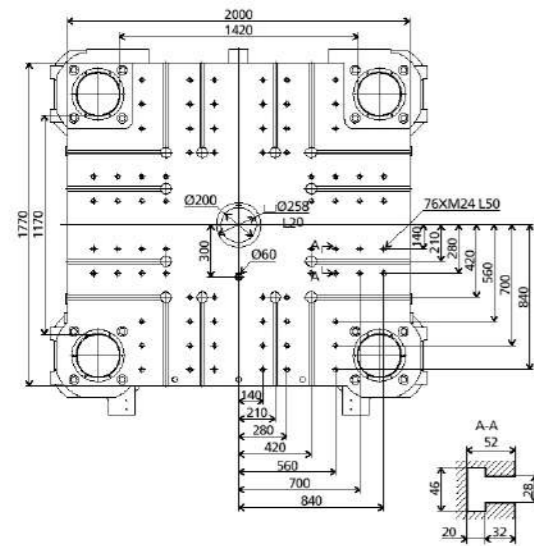

MOVING PLATEN DIMENSIONS

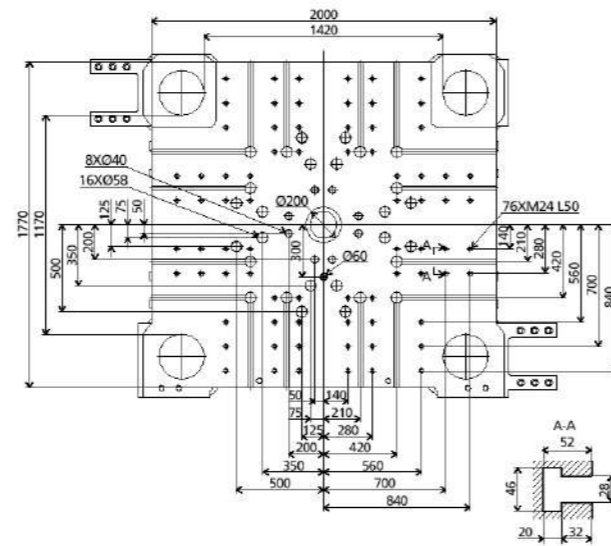

TOP VIEW

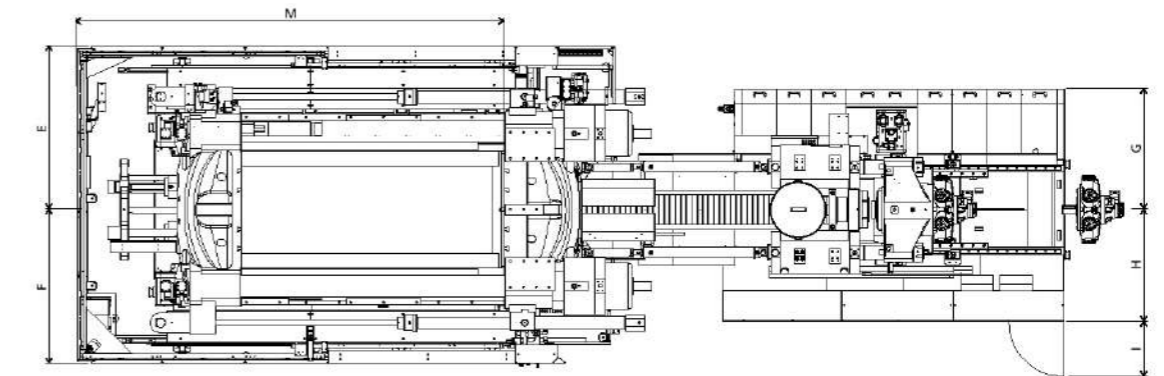

ROBOT MECHANICAL INTERFACE

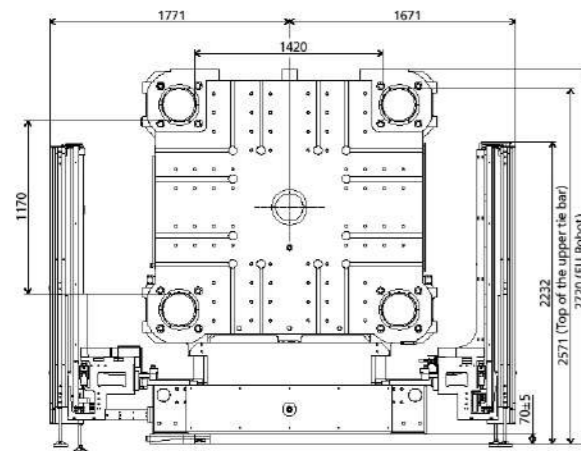

ROBOTTOP VIEW FIXED PLATEN

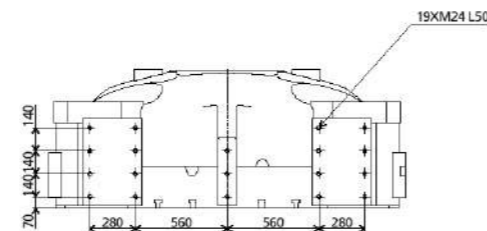

SIDE VIEW

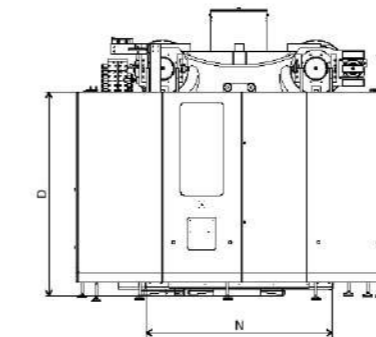

STANDARD

	INJECTION UNIT									DIMENSIONS (mm)			
	A	B	C	D	E	F	G	H	I	J	K	M	N
6750	2700	2571	3222	2200	1771	1671	1218	1065	596	5409	4792	4639	2002
8950	2770	2571	3283	2200	1771	1671	1218	1065	596	5409	4892	4639	2002
11500	2770	2571	4215	2200	1771	1671	1308	1215	596	5409	5378	4639	2002
17500	2770	2571	4487	2200	1771	1671	1875	1323	796	5409	5805	4639	2002



JU14000 V

MACHINE TYPE		JU14000 V															
CLAMPING UNIT	Clamping force	kN	14000														
	Mold opening stroke ①	mm	2350/1600														
	Mold height min.	mm	700														
	Mold height max.	mm	1450														
	Total daylight max.	mm	3050														
	Dist. between tie-bars (H×V)	mm	1470×1360														
	Ejector stroke	mm	400														
	Ejector force	kN	330														
	Mold weight max. ②	t	27														
INJECTION UNIT			6750			8950			11500				17500				
			A	B	C	A	B	C	A	B	C	D	A	B	C		
	Screw diameter	mm	90	100	110	100	110	120	110	120	130	140	130	140	150		
	Screw L/D ratio	L/D	24.4	22	20	24.2	22	20.2	26.2	24	22.2	20.6	24	22.3	20.8		
	Injection volume (theoretical)	cm ³	2990	3691	4466	4005	4846	5767	5226	6220	7300	8466	8362	9698	11133		
	Injection weight (PS)	g	2720	3359	4064	3645	4410	5248	4756	5660	6643	7704	7609	8825	10131		
	Injection rate (PS) ③	g/s	809	999	1209	797	965	1148	884	1052	1235	1432	1281	1486	1705		
	Injection pressure	MPa	193	156	129	196	162	136	189	159	135	117	185	160	139		
	Injection pressure (max)	MPa	222	180	148	223	184	154	217	183	156	134	210	181	158		
	Plasticizing rate (GPPS) ④	g/s	103.4	127.1	150.2	120.7	144.8	167.8	123.0	142.0	164.0	187.0	168.0	192.0	220.0		
Plasticizing rate (HDPE) ⑤	g/s	155.6	191.0	227.5	181.2	217.2	247.0	187.0	217.0	240.0	273.0	252.0	283.0	336.0			
Screw speed	rpm	170			155			105				102					
OTHERS	Pump motor power	kW	127			127			135				195				
	Heater power	kW	71			83			104				123				
	Machine dimension (L×W×H) ⑥	m	10.30×3.52×3.11			10.79×3.52×3.11			11.66×3.52×3.13				12.28×3.59×4.41				
	Machine weight	t	60			62			65				70				
	Hopper capacity (OP)	kg	100			200			400				400				
Oil tank ⑦	l	590			840			840				1670					

NOTE:

- ① With min. mold height / with max. mold height.
 ② Moving platen: 2/3 of max. mold weight.
 ③ The injection rate refers to the parameter in the differential injection condition.
 ④ Plasticizing capacity (GPPS): GB standard, with application of GPPS plasticizing capacity of 3-zone screws.
 ⑤ Plasticizing capacity (HDPE): Euromap 19, with application of HDPE plasticizing capacity of barrier screws.
 ⑥ The size is the net size of the machine, excluding the width of the feeding platform and the working platform.
 ⑦ The oil tank volume refers to the volume of the oil tank itself, excluding the volume in cylinder and pipeline. In this sense, the customer is advised to prepare the hydraulic oil according to 1.35 times of the oil tank volume.

The above plasticizing capacity is for reference only.

We reserve the right to make changes as a result of further technical advantages.

DIMENSIONS JU14000 V

CLAMPING UNIT

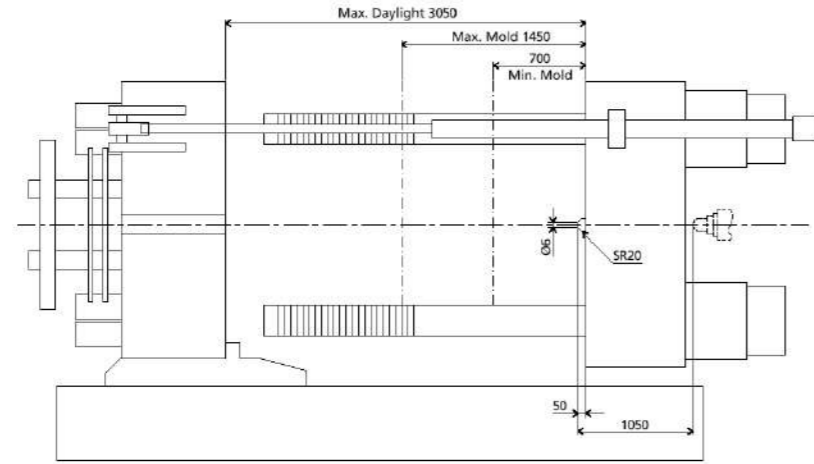

FRONT VIEW

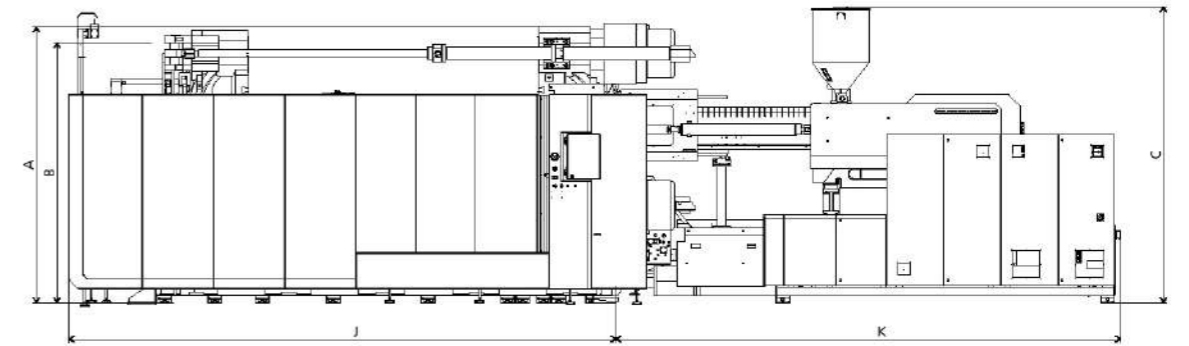

FIXED PLATEN DIMENSIONS

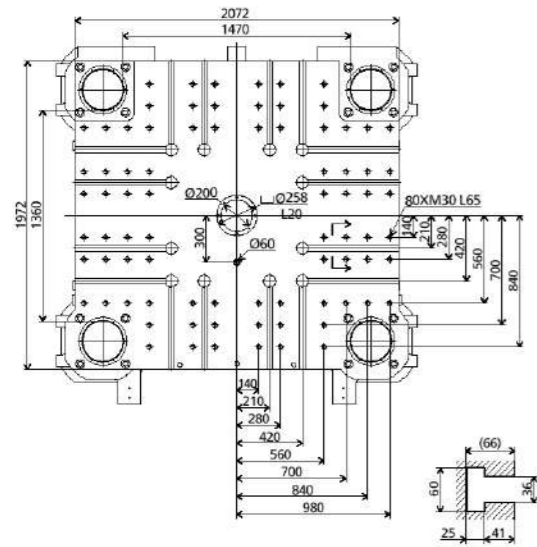

MOVING PLATEN DIMENSIONS

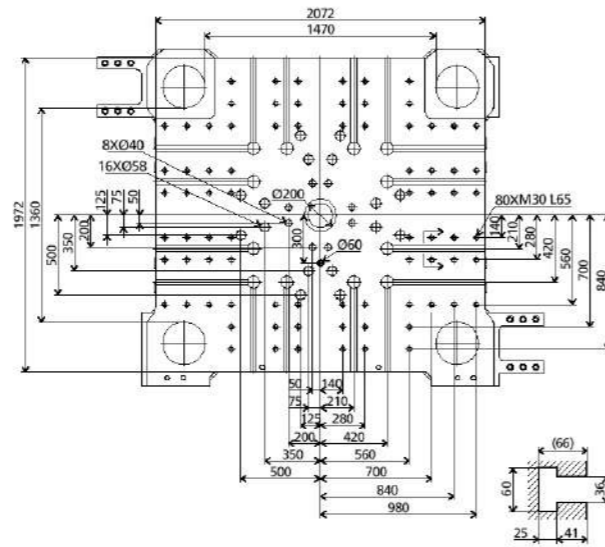

TOP VIEW

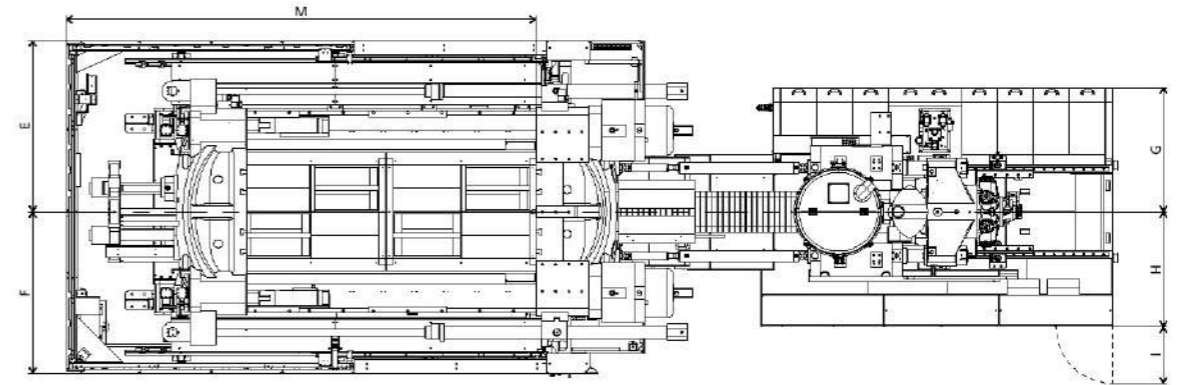

ROBOT MECHANICAL INTERFACE

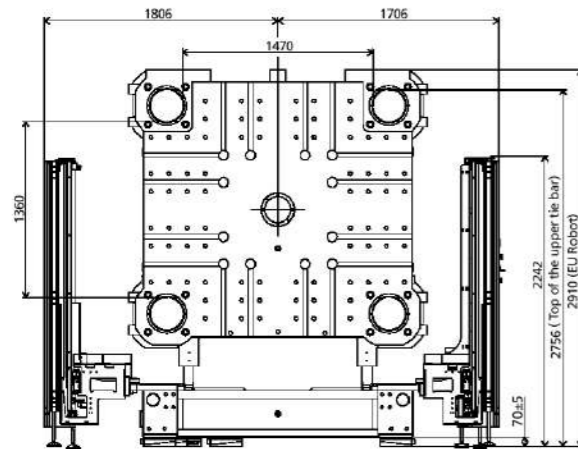

ROBOTTOP VIEW FIXED PLATEN

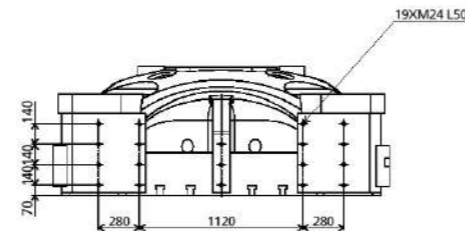

SIDE VIEW

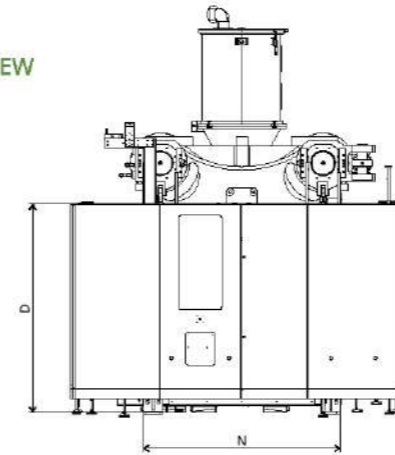

STANDARD

	INJECTION UNIT									DIMENSIONS (mm)			
	A	B	C	D	E	F	G	H	I	J	K	M	N
6750	2910	2756	3109	2200	1806	1706	1218	1065	596	5776	4792	4951	2072
8950	2910	2756	3109	2200	1806	1706	1218	1065	596	5776	4842	4951	2072
11500	2910	2756	3123	2200	1806	1706	1308	1215	596	5776	5328	4951	2072
17500	2910	2756	4408	2200	1806	1706	1875	1323	796	5776	5755	4951	2072



JU16000 V

MACHINE TYPE		JU16000 V												
CLAMPING UNIT	Clamping force	kN	16000											
	Mold opening stroke ①	mm	2550/1700											
	Mold height min.	mm	700											
	Mold height max.	mm	1550											
	Total daylight max.	mm	3250											
	Dist. between tie-bars (H×V)	mm	1570×1285											
	Ejector stroke	mm	400											
	Ejector force	kN	330											
	Mold weight max. ②	t	33											
			8950			11500			17500					
			A	B	C	A	B	C	D	A	B	C		
INJECTION UNIT	Screw diameter	mm	100	110	120	110	120	130	140	130	140	150		
	Screw L/D ratio	L/D	24.2	22	20.2	26.2	24	22.2	20.6	24	22.3	20.8		
	Injection volume (theoretical)	cm ³	4005	4846	5767	5226	6220	7300	8466	8362	9698	11133		
	Injection weight (PS)	g	3645	4410	5248	4756	5660	6643	7704	7609	8825	10131		
	Injection rate (PS) ③	g/s	855	1034	1231	884	1052	1235	1432	1281	1486	1705		
	Injection pressure	MPa	196	162	136	189	159	135	117	185	160	139		
	Injection pressure (max)	MPa	223	184	154	217	183	156	134	210	181	158		
	Plasticizing rate (GPPS) ④	g/s	120.7	144.8	167.8	123.0	142.0	164.0	187.0	168.0	192.0	220.0		
	Plasticizing rate (HDPE) ⑤	g/s	181.2	217.2	247.0	187.0	217.0	240.0	273.0	252.0	283.0	336.0		
Screw speed	rpm		155			105				102				
OTHERS	Pump motor power	kW		135			135				195			
	Heater power	kW		83			104				123			
	Machine dimension (L×W×H) ⑥	m		11.27×3.73×3.11			11.83×3.73×3.11			12.45×3.73×4.37				
	Machine weight	t		69			71				76			
	Hopper capacity (OP)	kg		200			400				400			
Oil tank ⑦	l		840			840				1670				

NOTE:

- ① With min. mold height / with max. mold height.
- ② Moving platen: 2/3 of max. mold weight.
- ③ The injection rate refers to the parameter in the differential injection condition.
- ④ Plasticizing capacity (GPPS): GB standard, with application of GPPS plasticizing capacity of 3-zone screws.
- ⑤ Plasticizing capacity (HDPE): Euromap 19, with application of HDPE plasticizing capacity of barrier screws.
- ⑥ The size is the net size of the machine, excluding the width of the feeding platform and the working platform.
- ⑦ The oil tank volume refers to the volume of the oil tank itself, excluding the volume in cylinder and pipeline. In this sense, the customer is advised to prepare the hydraulic oil according to 1.35 times of the oil tank volume.

The above plasticizing capacity is for reference only.

We reserve the right to make changes as a result of further technical advantages.



DIMENSIONS JU16000 V

CLAMPING UNIT

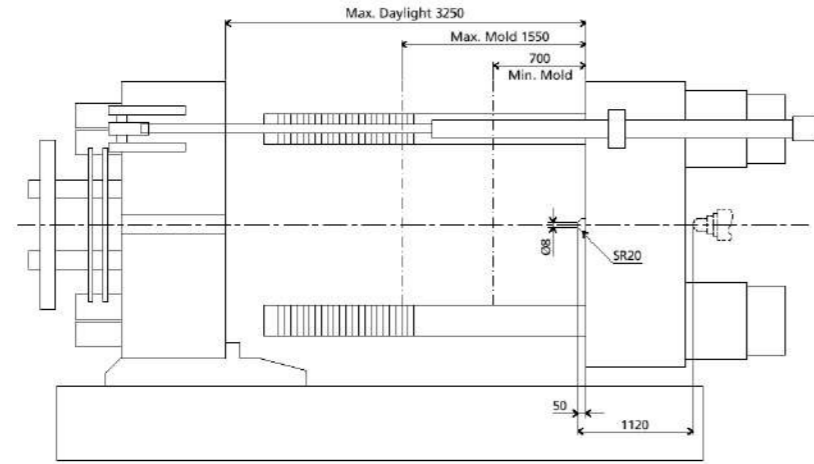

FRONT VIEW

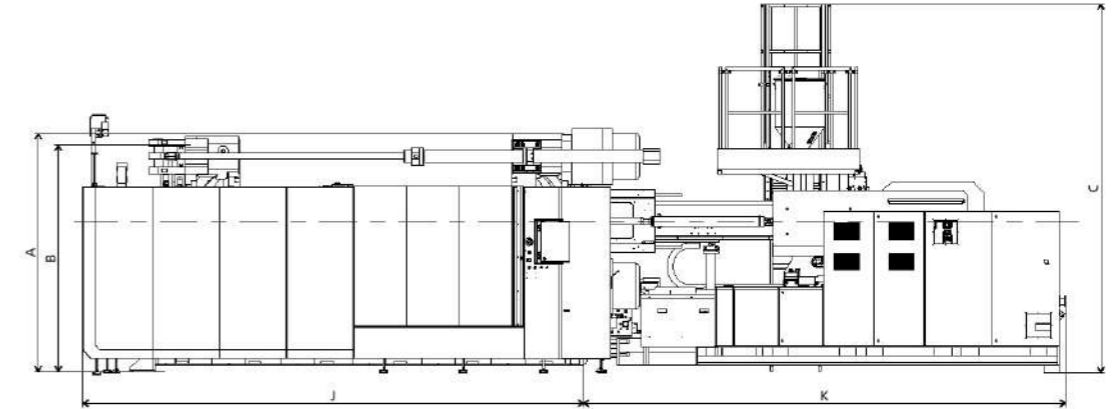

FIXED PLATEN DIMENSIONS

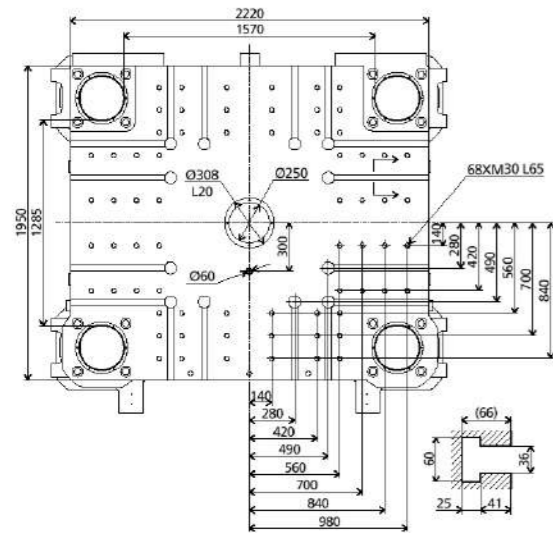

MOVING PLATEN DIMENSIONS

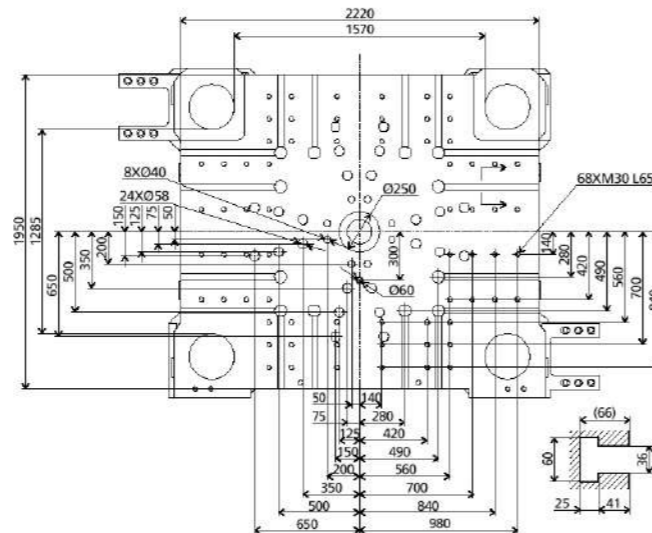

TOP VIEW

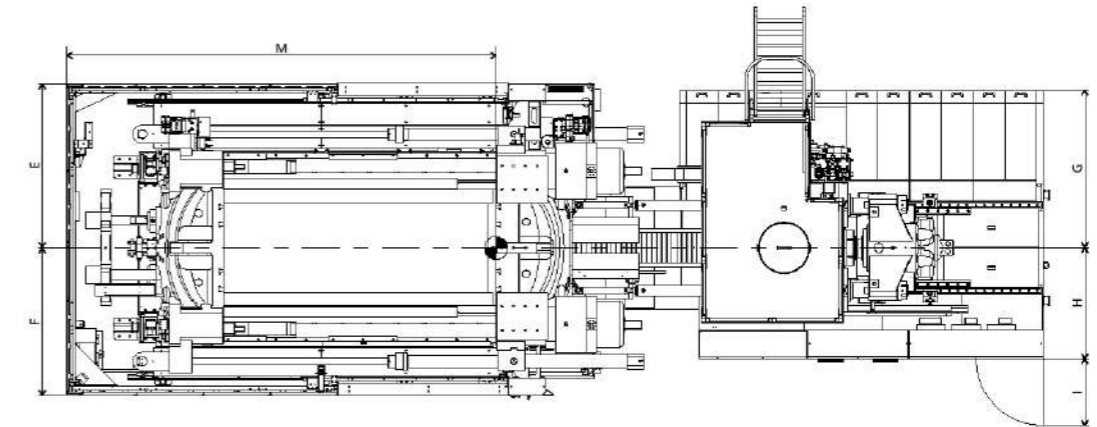

ROBOT MECHANICAL INTERFACE

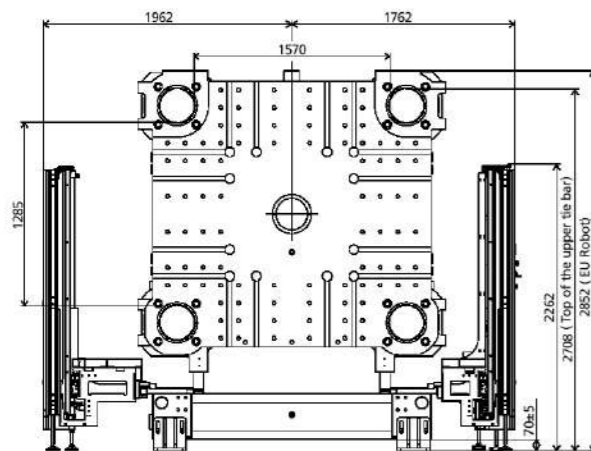

ROBOTTOP VIEW FIXED PLATEN

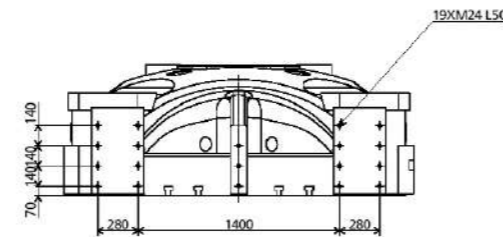

SIDE VIEW

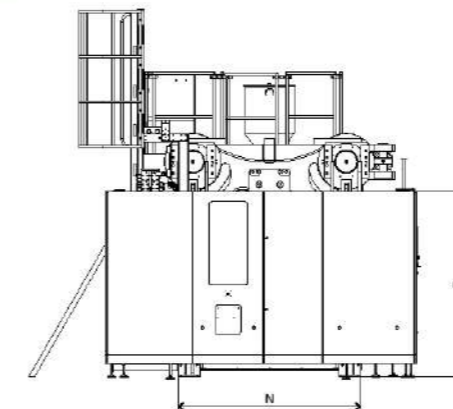

STANDARD

	INJECTION UNIT												
	A	B	C	D	E	F	G	H	I	J	K	M	N
8950	2832	2688	3109	2200	1962	1762	1218	1065	596	5976	4842	5121	2184
11500	2832	2688	3109	2200	1962	1762	1308	1215	596	5976	5378	5121	2184
17500	2832	2688	4363	2200	1962	1762	1875	1323	796	5976	5755	5121	2184



JU18500 V

MACHINE TYPE		JU18500 V														
CLAMPING UNIT	Clamping force	kN	18500													
	Mold opening stroke ①	mm	2600/1750													
	Mold height min.	mm	750													
	Mold height max.	mm	1600													
	Total daylight max.	mm	3350													
	Dist. between tie-bars (H×V)	mm	1900×1450													
	Ejector stroke	mm	450													
	Ejector force	kN	450													
	Mold weight max. ②	t	40													
INJECTION UNIT			11500				17500				22500				32500	
			A	B	C	D	A	B	C	A	B	C	D	A	B	
	Screw diameter	mm	110	120	130	140	130	140	150	140	150	160	170	160	170	
	Screw L/D ratio	L/D	26.2	24	22.2	20.6	24	22.3	20.8	24	22.4	21	19.8	24	22.6	
	Injection volume (theoretical)	cm ³	5226	6220	7300	8466	8362	9698	11133	10467	12016	13672	15434	17492	19747	
	Injection weight (PS)	g	4756	5660	6643	7704	7609	8825	10131	9525	10935	12441	14045	15918	17970	
	Injection rate (PS) ③	g/s	884	1052	1235	1432	1281	1486	1705	1352	1552	1766	1994	1559	1761	
	Injection pressure	MPa	189	159	135	117	185	160	139	185	161	141	125	160	142	
	Injection pressure (max)	MPa	217	183	156	134	210	181	158	211	184	161	143	180	159	
	Plasticizing rate (GPPS) ④	g/s	123.0	142.0	164.0	187.0	168.0	192.0	220.0	155.0	176.0	196.0	222.0	\	\	
Plasticizing rate (HDPE) ⑤	g/s	187.0	217.0	240.0	273.0	252.0	283.0	336.0	243.0	294.0	303.0	334.0	280.0	310.0		
Screw speed	rpm	105				102				85				72		
OTHERS	Pump motor power	kW	135				195				205				205	
	Heater power	kW	104				123				137				189	
	Machine dimension (L×W×H) ⑥	m	11.52×4.03×3.34				12.70×4.03×4.40				12.93×4.03×4.40				13.88×4.03×4.40	
	Machine weight	t	83				87				92				94	
	Hopper capacity (OP)	kg	400				400				400				400	
	Oil tank ⑦	l	840				1670				1670				1670	

NOTE:

- ① With min. mold height / with max. mold height.
- ② Moving platen: 2/3 of max. mold weight.
- ③ The injection rate refers to the parameter in the differential injection condition.
- ④ Plasticizing capacity (GPPS): GB standard, with application of GPPS plasticizing capacity of 3-zone screws.
- ⑤ Plasticizing capacity (HDPE): Euromap 19, with application of HDPE plasticizing capacity of barrier screws.
- ⑥ The size is the net size of the machine, excluding the width of the feeding platform and the working platform.
- ⑦ The oil tank volume refers to the volume of the oil tank itself, excluding the volume in cylinder and pipeline. In this sense, the customer is advised to prepare the hydraulic oil according to 1.35 times of the oil tank volume.

The above plasticizing capacity is for reference only.

We reserve the right to make changes as a result of further technical advantages.



DIMENSIONS JU18500 V

CLAMPING UNIT

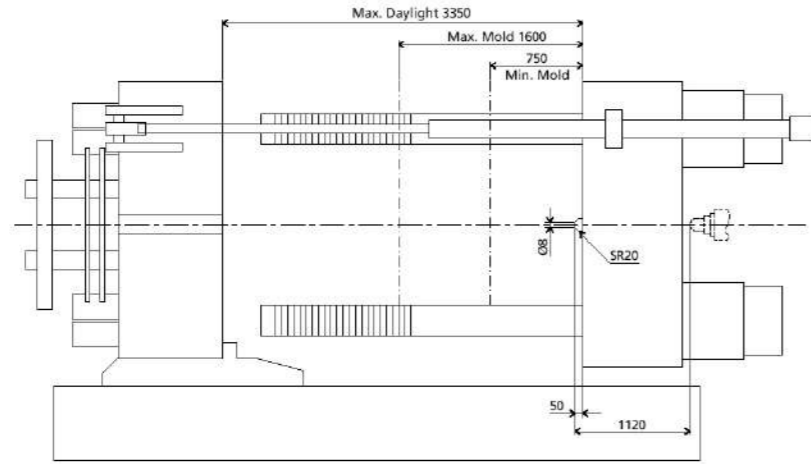

FRONT VIEW

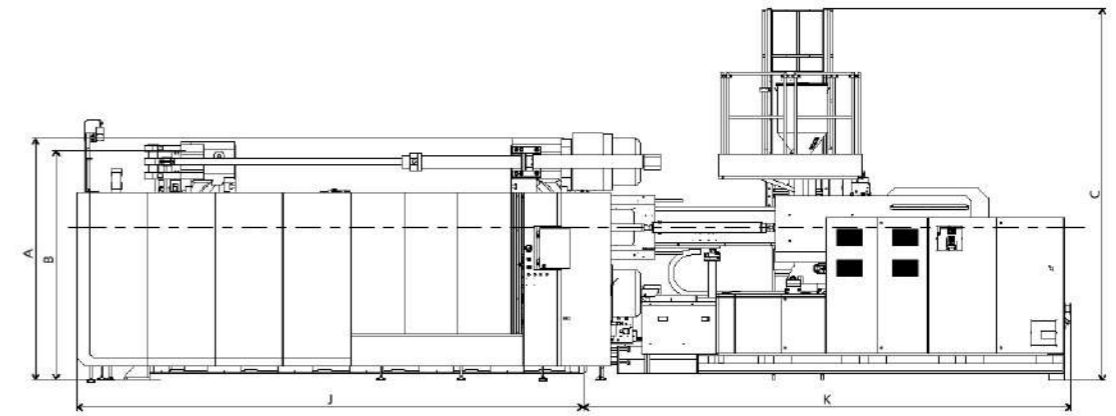

FIXED PLATEN DIMENSIONS

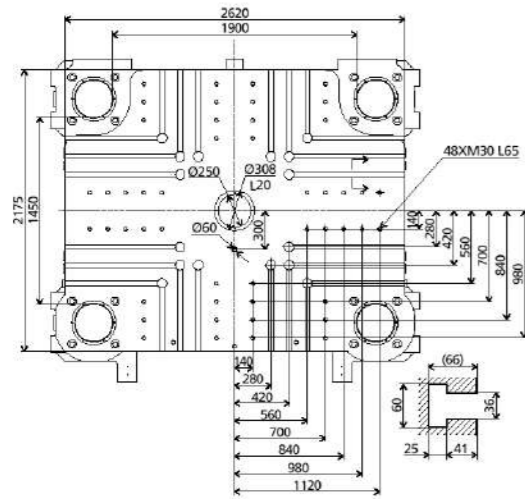

MOVING PLATEN DIMENSIONS

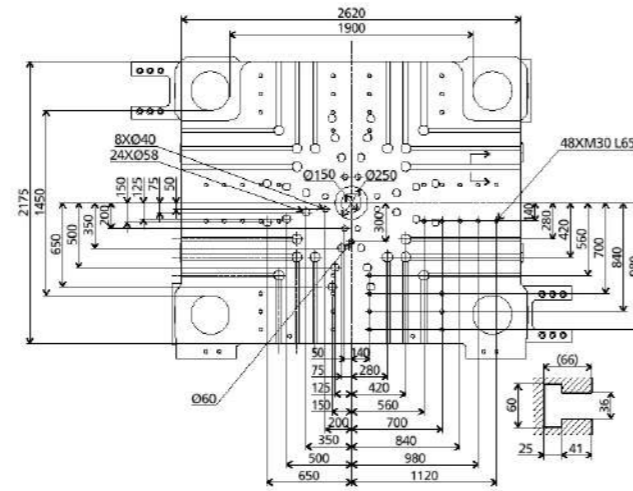

TOP VIEW

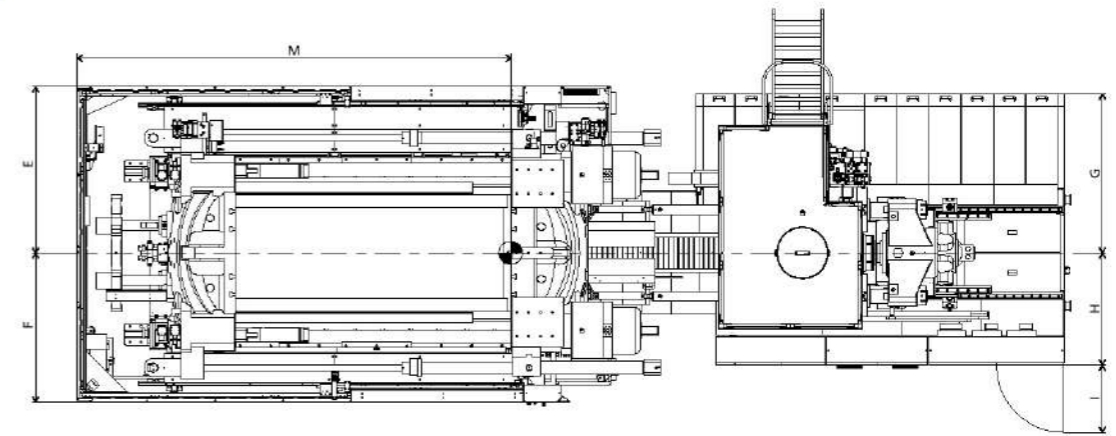

ROBOT MECHANICAL INTERFACE

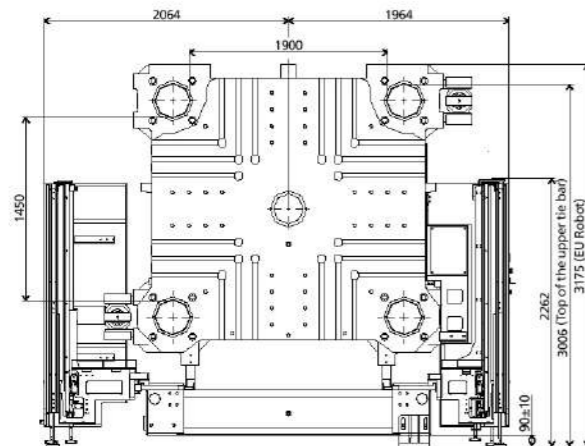

ROBOTTOP VIEW FIXED PLATEN

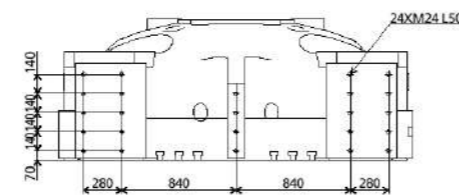

SIDE VIEW

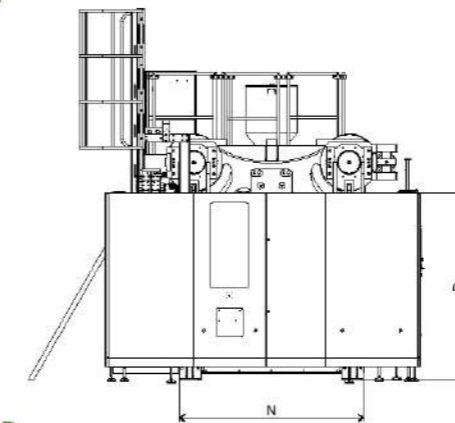

STANDARD

	INJECTION UNIT								DIMENSIONS (mm)				
	A	B	C	D	E	F	G	H	I	J	K	M	N
11500	3175	3006	3330	2220	2064	1964	1308	1215	596	6356	5378	5371	2388
17500	3175	3006	4393	2220	2064	1964	1875	1323	796	6356	5655	5371	2388
22500	3175	3006	4393	2220	2064	1964	1935	1422	796	6356	6210	5371	2388
32500	3175	3006	4393	2220	2064	1964	1935	1422	796	6356	7228	5371	2388



JU21000 V

MACHINE TYPE		JU21000 V																
CLAMPING UNIT	Clamping force	kN	21000															
	Mold opening stroke ①	mm	2700/1800															
	Mold height min.	mm	800															
	Mold height max.	mm	1700															
	Total daylight max.	mm	3500															
	Dist. between tie-bars (H×V)	mm	1920×1480															
	Ejector stroke	mm	450															
	Ejector force	kN	450															
	Mold weight max. ②	t	50															
INJECTION UNIT			11500				17500			22500			32500		40500			
			A	B	C	D	A	B	C	A	B	C	D	A	B	A	B	
	Screw diameter	mm	110	120	130	140	130	140	150	140	150	160	170	160	170	170	185	
	Screw L/D ratio	L/D	26.2	24	22.2	20.6	24	22.3	20.8	24	22.4	21	19.8	24	22.6	23.5	21.6	
	Injection volume (theoretical)	cm ³	5226	6220	7300	8466	8362	9698	11133	10467	12016	13672	15434	17492	19747	23378	27686	
	Injection weight (PS)	g	4756	5660	6643	7704	7609	8825	10131	9525	10935	12441	14045	15918	17970	21274	25194	
	Injection rate (PS) ③	g/s	1255	1493	1753	2033	1281	1486	1705	1352	1552	1766	1994	1559	1761	1576	1867	
	Injection pressure	MPa	189	159	135	117	185	160	139	185	161	141	125	160	142	159	134	
	Injection pressure (max)	MPa	217	183	156	134	210	181	158	211	184	161	143	180	159	179	151	
	Plasticizing rate (GPPS) ④	g/s	123.0	142.0	164.0	187.0	168.0	192.0	220.0	155.0	176.0	196.0	222.0	\	\	\	\	
	Plasticizing rate (HDPE) ⑤	g/s	187.0	217.0	240.0	273.0	252.0	283.0	336.0	243.0	294.0	303.0	334.0	280.0	310.0	309.0	320.0	
Screw speed	rpm	125				102			85			72		70				
OTHERS	Pump motor power	kW	195				195			205			205		205			
	Heater power	kW	104				123			137			189		211			
	Machine dimension (L×W×H) ⑥	m	12.77×5.07×3.38				12.77×5.07×4.38			13.00×5.07×4.38			13.95×5.07×4.39		14.78×5.07×4.38			
	Machine weight	t	94				98			102			105		112			
	Hopper capacity (OP)	kg	400				400			400			400		400			
	Oil tank ⑦	l	840				1670			1670			1670		1670			

NOTE:

- ① With min. mold height / with max. mold height.
- ② Moving platen: 2/3 of max. mold weight.
- ③ The injection rate refers to the parameter in the differential injection condition.
- ④ Plasticizing capacity (GPPS): GB standard, with application of GPPS plasticizing capacity of 3-zone screws.
- ⑤ Plasticizing capacity (HDPE): Euromap 19, with application of HDPE plasticizing capacity of barrier screws.
- ⑥ The size is the net size of the machine, excluding the width of the feeding platform and the working platform.
- ⑦ The oil tank volume refers to the volume of the oil tank itself, excluding the volume in cylinder and pipeline. In this sense, the customer is advised to prepare the hydraulic oil according to 1.35 times of the oil tank volume.

The above plasticizing capacity is for reference only.

We reserve the right to make changes as a result of further technical advantages.



DIMENSIONS JU21000 V

CLAMPING UNIT

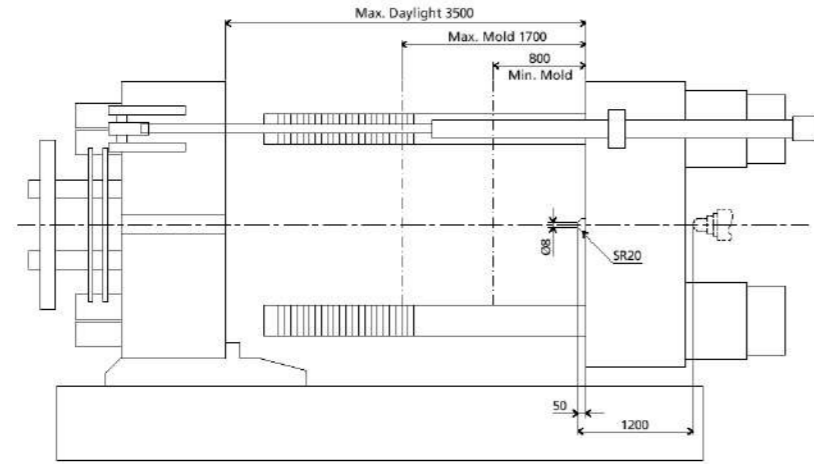

FRONT VIEW

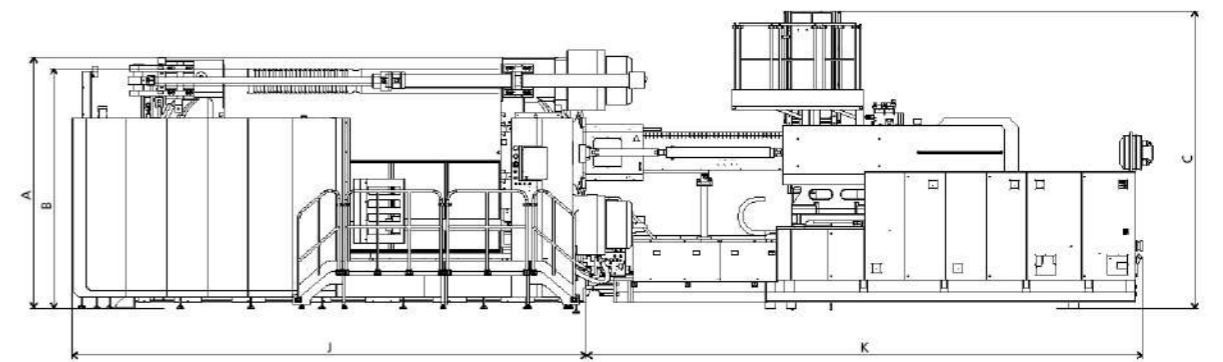

FIXED PLATEN DIMENSIONS

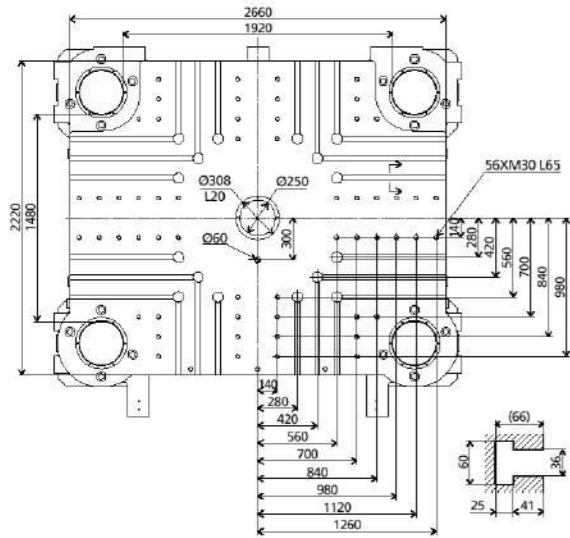

MOVING PLATEN DIMENSIONS

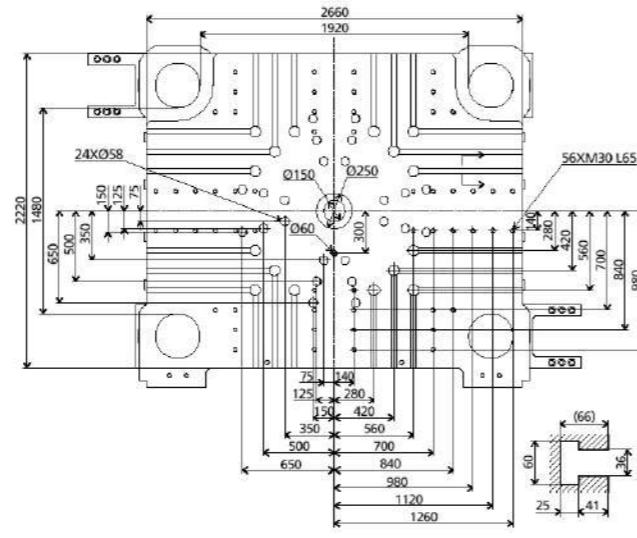

TOP VIEW

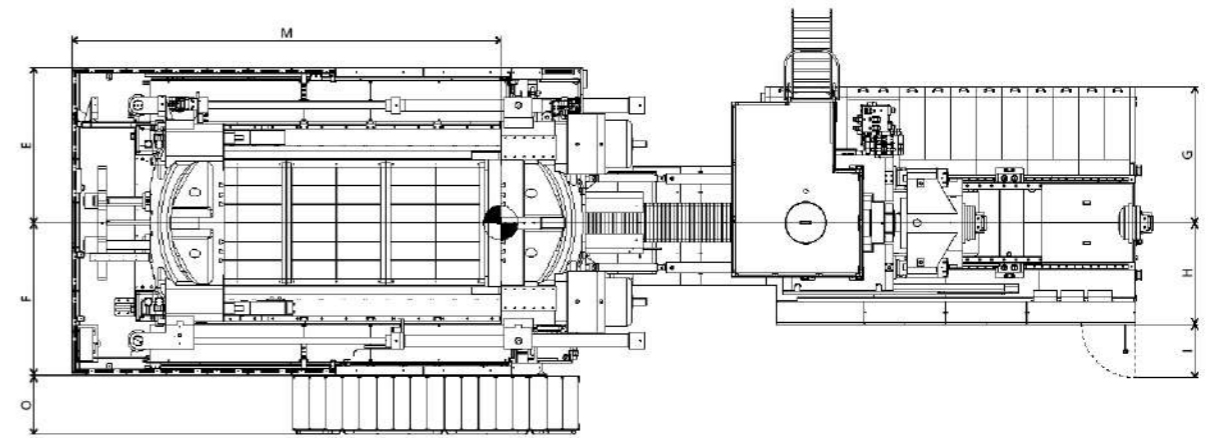

ROBOT MECHANICAL INTERFACE

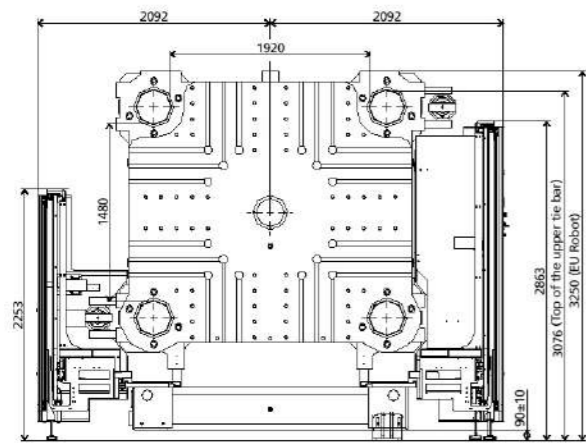

ROBOTTOP VIEW FIXED PLATEN

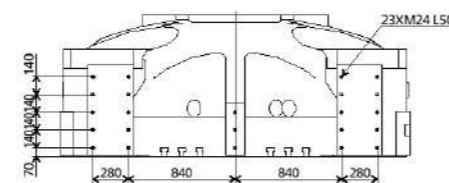

SIDE VIEW

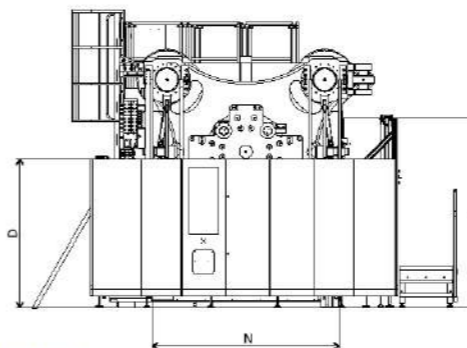

STANDARD

	INJECTION UNIT										DIMENSIONS (mm)				
	A	B	C	D	E	F	G	H	I	J	K	L	M	N	O
11500	3250	3076	3370	2202	2092	2092	1815	1215	596	6425	5755	2812	5440	2442	864
17500	3250	3076	4377	2202	2092	2092	1875	1323	796	6425	5755	2812	5440	2442	864
22500	3250	3076	4377	2202	2092	2092	1935	1422	796	6425	6260	2812	5440	2442	864
32500	3250	3076	4387	2202	2092	2092	1935	1422	796	6425	7278	2812	5440	2442	864
40500	3250	3076	4377	2202	2092	2092	1965	1452	796	6425	7966	2812	5440	2442	864



JU24000 V

MACHINE TYPE		JU24000 V														
CLAMPING UNIT	Clamping force	kN	24000													
	Mold opening stroke ①	mm	3000/2000													
	Mold height min.	mm	800													
	Mold height max.	mm	1800													
	Total daylight max.	mm	3800													
	Dist. between tie-bars (H×V)	mm	2020×1620													
	Ejector stroke	mm	500													
	Ejector force	kN	450													
	Mold weight max. ②	t	59													
INJECTION UNIT			17500			22500			32500			40500				
			A	B	C	A	B	C	D	A	B	A	B			
	Screw diameter	mm	130	140	150	140	150	160	170	160	170	170	185			
	Screw L/D ratio	L/D	24	22.3	20.8	24	22.4	21	19.8	24	22.6	23.5	21.6			
	Injection volume (theoretical)	cm ³	8362	9698	11133	10467	12016	13672	15434	17492	19747	23378	27686			
	Injection weight (PS)	g	7609	8825	10131	9525	10935	12441	14045	15918	17970	21274	25194			
	Injection rate (PS) ③	g/s	1348	1564	1795	1352	1552	1766	1994	1559	1761	1576	1867			
	Injection pressure	MPa	185	160	139	185	161	141	125	160	142	159	134			
	Injection pressure (max)	MPa	210	181	158	211	184	161	143	180	159	179	151			
	Plasticizing rate (GPPS) ④	g/s	168.0	192.0	220.0	155.0	176.0	196.0	222.0	\	\	\	\			
Plasticizing rate (HDPE) ⑤	g/s	252.0	283.0	336.0	243.0	294.0	303.0	334.0	280.0	310.0	309.0	320.0				
Screw speed	rpm	114			85			72			70					
OTHERS	Pump motor power	kW	205			205			205			205				
	Heater power	kW	123			137			189			211				
	Machine dimension (L×W×H) ⑥	m	13.21×5.29×4.36			13.45×5.29×4.36			14.40×5.29×4.36			15.23×5.29×4.36				
	Machine weight	t	114			118			121			129				
	Hopper capacity (OP)	kg	400			400			400			400				
Oil tank ⑦	l	1670			1670			1670			1670					

NOTE:

- ① With min. mold height / with max. mold height.
- ② Moving platen: 2/3 of max. mold weight.
- ③ The injection rate refers to the parameter in the differential injection condition.
- ④ Plasticizing capacity (GPPS): GB standard, with application of GPPS plasticizing capacity of 3-zone screws.
- ⑤ Plasticizing capacity (HDPE): Euromap 19, with application of HDPE plasticizing capacity of barrier screws.
- ⑥ The size is the net size of the machine, excluding the width of the feeding platform and the working platform.
- ⑦ The oil tank volume refers to the volume of the oil tank itself, excluding the volume in cylinder and pipeline. In this sense, the customer is advised to prepare the hydraulic oil according to 1.35 times of the oil tank volume.

The above plasticizing capacity is for reference only.

We reserve the right to make changes as a result of further technical advantages.



DIMENSIONS JU24000 V

CLAMPING UNIT

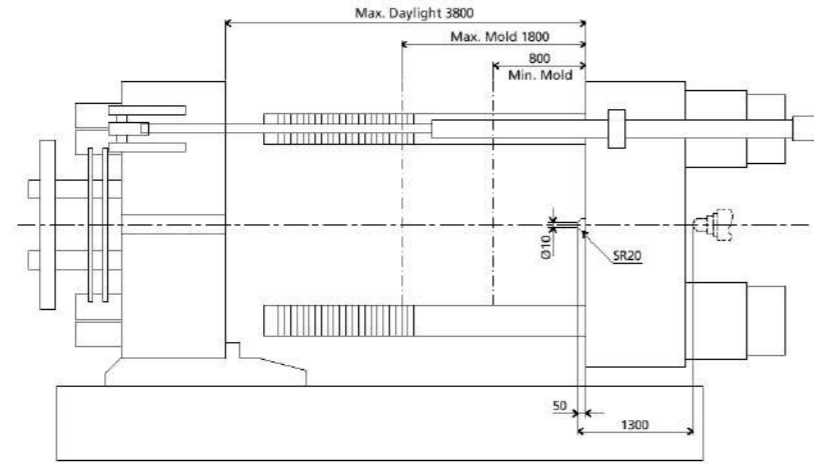

FRONT VIEW

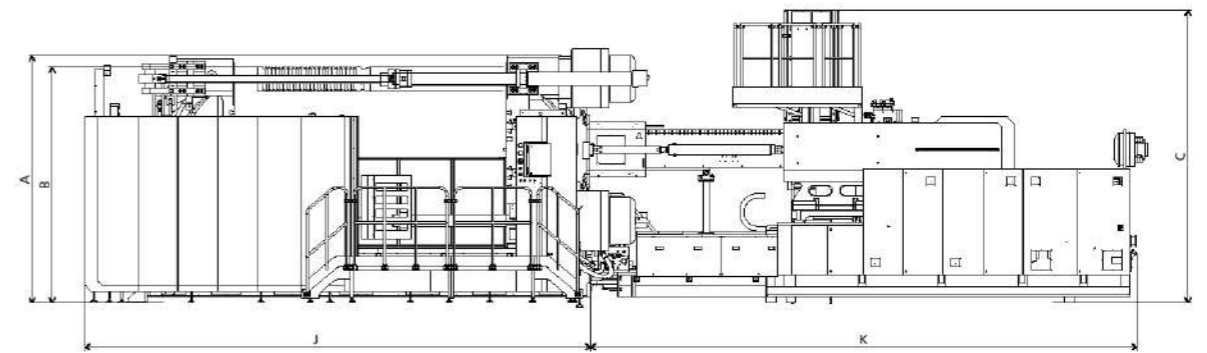

FIXED PLATEN DIMENSIONS

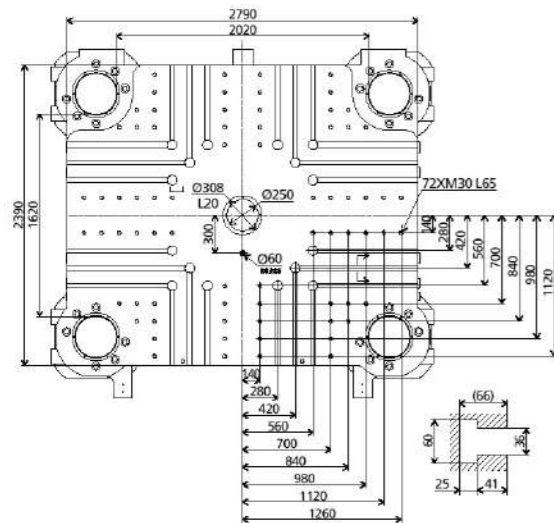

MOVING PLATEN DIMENSIONS

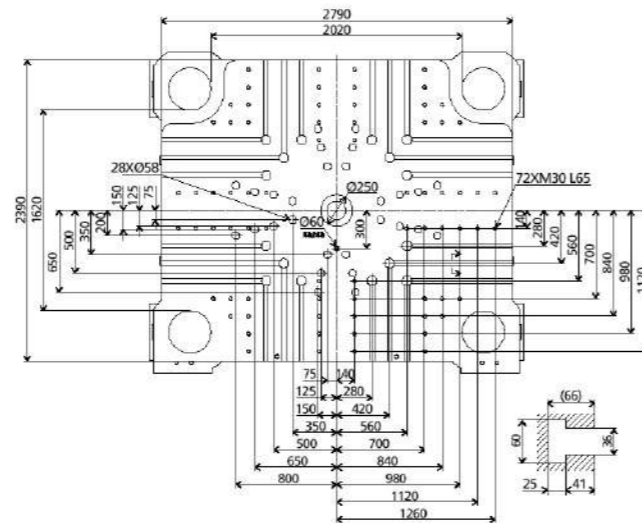

TOP VIEW

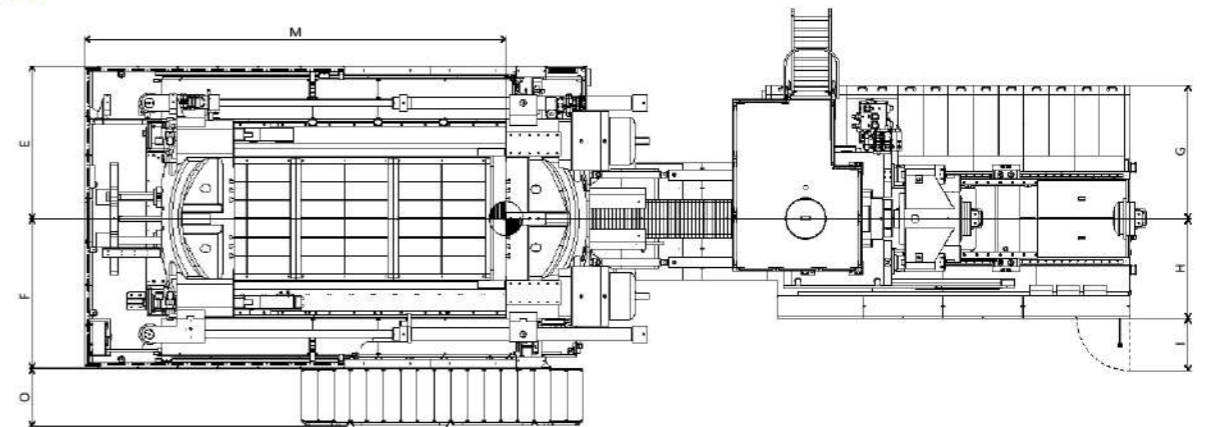

ROBOT MECHANICAL INTERFACE

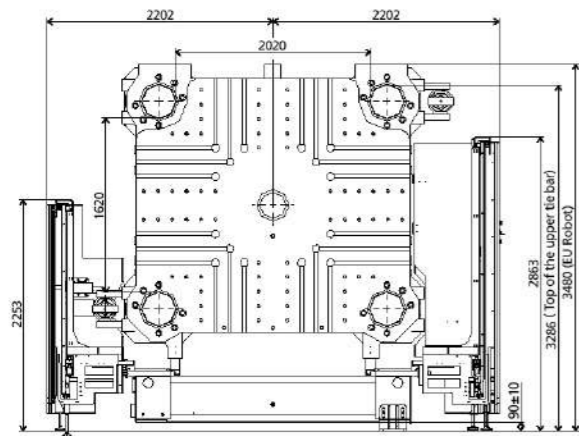

ROBOTTOP VIEW FIXED PLATEN

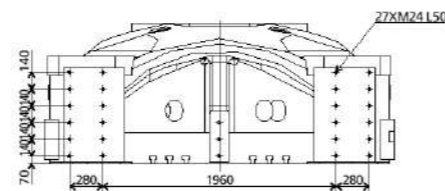

SIDE VIEW

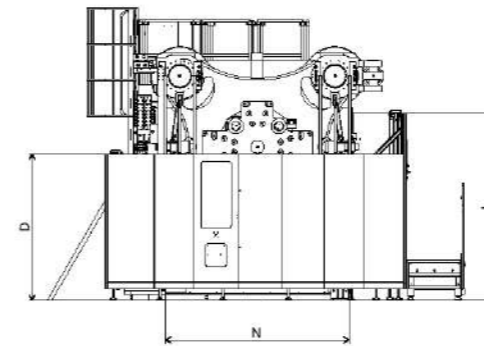

STANDARD

	INJECTION UNIT										DIMENSIONS (mm)				
	A	B	C	D	E	F	G	H	I	J	K	L	M	N	O
17500	3480	3286	4360	2202	2202	2202	1875	1323	796	7081	5655	2812	5886	2672	864
22500	3480	3286	4360	2202	2202	2202	1935	1422	796	7081	6210	2812	5886	2672	864
32500	3480	3286	4360	2202	2202	2202	1935	1422	796	7081	7178	2812	5886	2672	864
40500	3480	3286	4360	2202	2202	2202	1965	1452	796	7081	7766	2812	5886	2672	864



JU28000 V

MACHINE TYPE		JU28000 V											
CLAMPING UNIT	Clamping force	kN	28000										
	Mold opening stroke ①	mm	3300/2100										
	Mold height min.	mm	800										
	Mold height max.	mm	2000										
	Total daylight max.	mm	4100										
	Dist. between tie-bars (H×V)	mm	2185×1755										
	Ejector stroke	mm	500										
	Ejector force	kN	450										
	Mold weight max. ②	t	66										
INJECTION UNIT			22500				32500			40500		50500	62500
			A	B	C	D	A	B	A	B	B	B	
	Screw diameter	mm	140	150	160	170	160	170	170	185	200	220	
	Screw L/D ratio	L/D	24	22.4	21	19.8	24	22.6	23.5	21.6	20	20.5	
	Injection volume (theoretical)	cm ³	10467	12016	13672	15434	17492	19747	23378	27686	35185	45615	
	Injection weight (PS)	g	9525	10935	12441	14045	15918	17970	21274	25194	32019	41510	
	Injection rate (PS) ③	g/s	1352	1552	1766	1994	1559	1761	1576	1867	2386	2617	
	Injection pressure	MPa	185	161	141	125	160	142	159	134	132	120	
	Injection pressure (max)	MPa	211	184	161	143	180	159	179	151	147	135	
	Plasticizing rate (GPPS) ④	g/s	155.0	176.0	196.0	222.0	\	\	\	\	\	\	
Plasticizing rate (HDPE) ⑤	g/s	243.0	294.0	303.0	334.0	280.0	310.0	309.0	320.0	380.0	370.0		
Screw speed	rpm	94				81			70		70	53	
OTHERS	Pump motor power	kW	205				205			205		255	255
	Heater power	kW	137				189			211		211	228
	Machine dimension (L×W×H) ⑥	m	13.91×5.43×4.42				14.86×5.43×4.42			15.69×5.43×4.42		16.02×5.43×4.42	16.57×5.43×4.42
	Machine weight	t	138				141			148		153	156
	Hopper capacity (OP)	kg	400				400			400		400	400
	Oil tank ⑦	l	1670				1670			1670		2800	2800

NOTE:

- ① With min. mold height / with max. mold height.
- ② Moving platen: 2/3 of max. mold weight.
- ③ The injection rate refers to the parameter in the differential injection condition.
- ④ Plasticizing capacity (GPPS): GB standard, with application of GPPS plasticizing capacity of 3-zone screws.
- ⑤ Plasticizing capacity (HDPE): Euromap 19, with application of HDPE plasticizing capacity of barrier screws.
- ⑥ The size is the net size of the machine, excluding the width of the feeding platform and the working platform.
- ⑦ The oil tank volume refers to the volume of the oil tank itself, excluding the volume in cylinder and pipeline. In this sense, the customer is advised to prepare the hydraulic oil according to 1.35 times of the oil tank volume.

The above plasticizing capacity is for reference only.

We reserve the right to make changes as a result of further technical advantages.



DIMENSIONS JU28000 V

CLAMPING UNIT

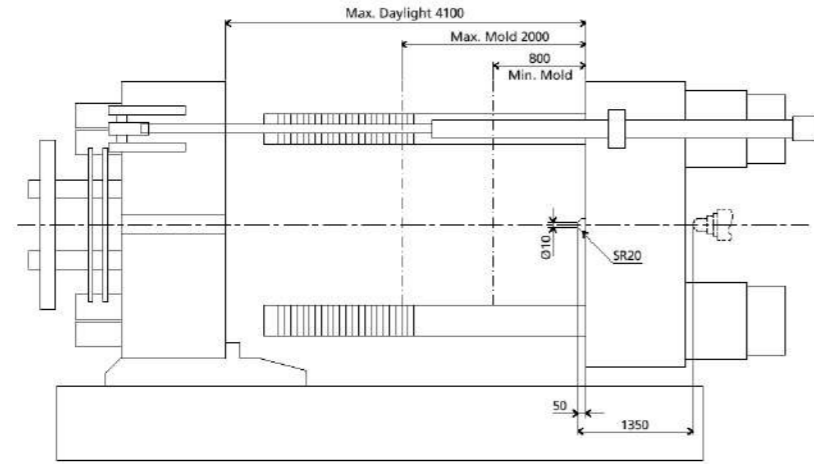

FRONT VIEW

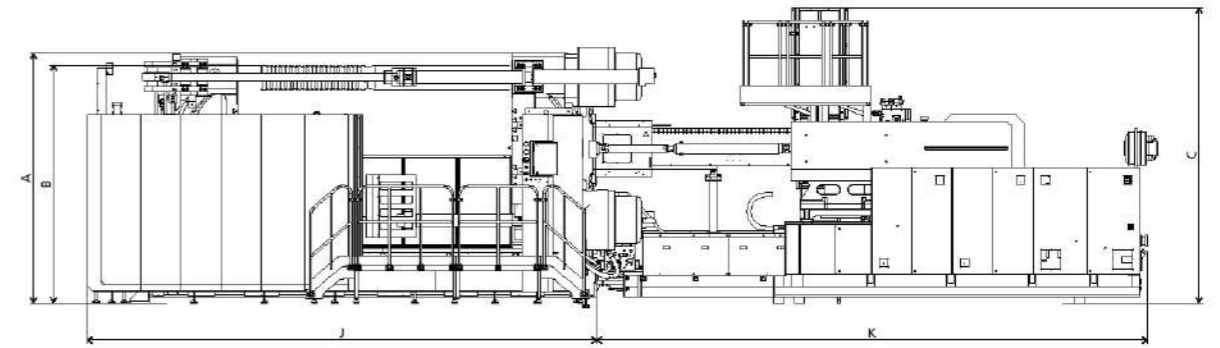

FIXED PLATEN DIMENSIONS

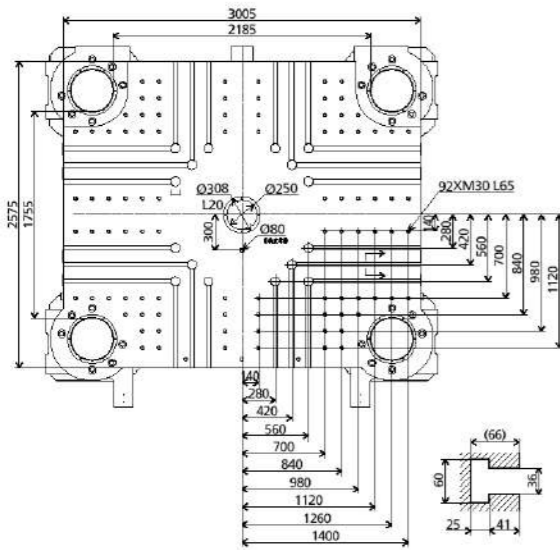

MOVING PLATEN DIMENSIONS

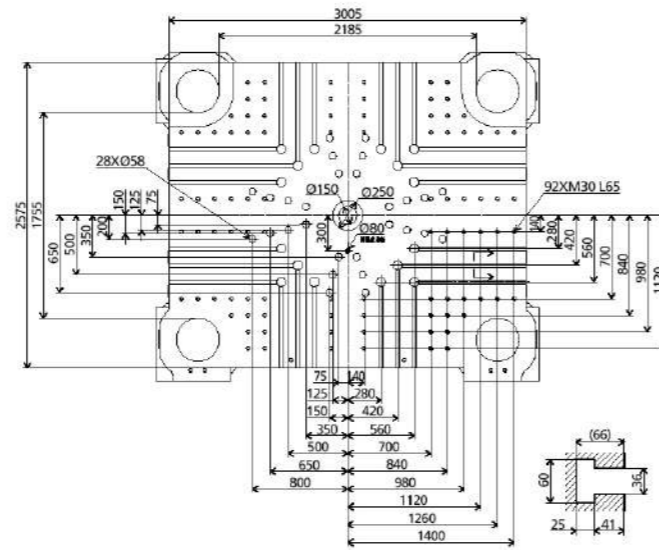

TOP VIEW

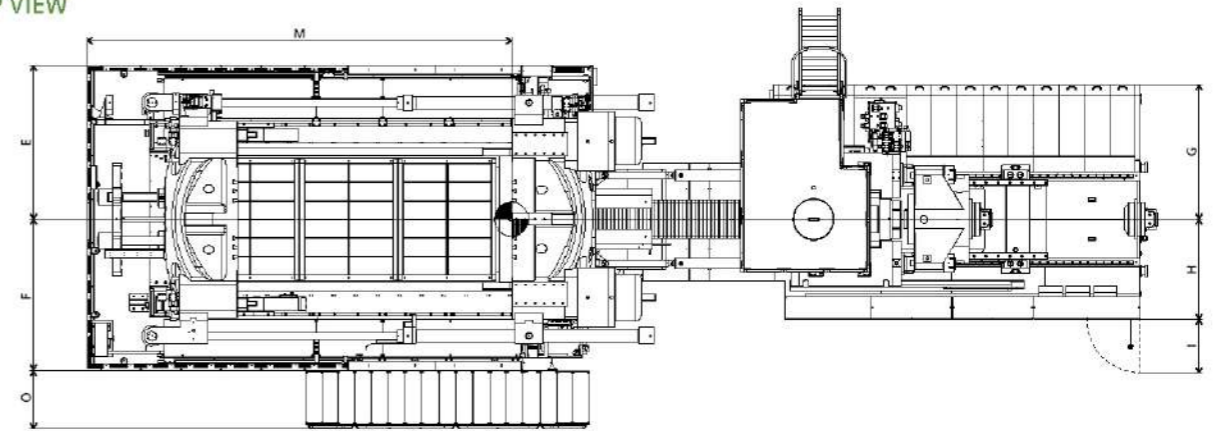

ROBOT MECHANICAL INTERFACE

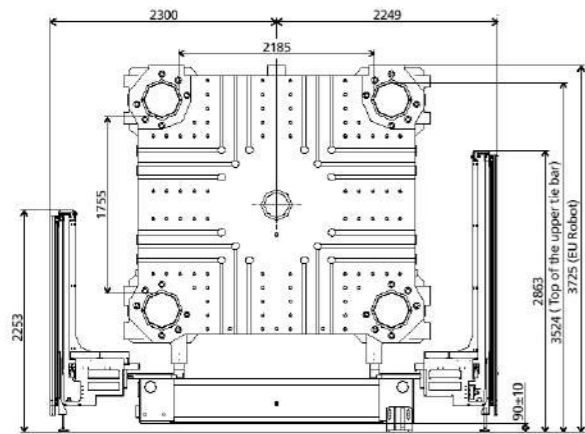

ROBOTTOP VIEW FIXED PLATEN

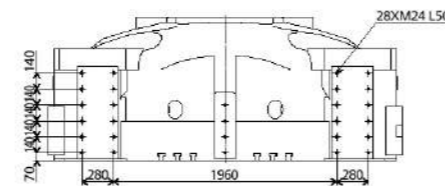

SIDE VIEW

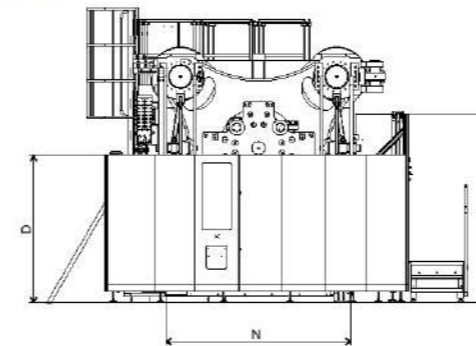

STANDARD

	INJECTION UNIT										DIMENSIONS (mm)				
	A	B	C	D	E	F	G	H	I	J	K	L	M	N	O
22500	3725	3524	4411	2202	2300	2249	1935	1422	796	7620	6160	2812	6350	2767	864
32500	3725	3524	4411	2202	2300	2249	1935	1422	796	7620	7178	2812	6350	2767	864
40500	3725	3524	4411	2202	2300	2249	1965	1452	796	7620	7766	2812	6350	2767	864
50500	3725	3524	4411	2202	2300	2249	2010	1497	796	7620	8228	2812	6350	2767	864
62500	3725	3524	4411	2202	2300	2249	2010	1497	796	7620	8778	2812	6350	2767	864



JU33000 V

MACHINE TYPE		JU33000 V											
CLAMPING UNIT	Clamping force	kN	33000										
	Mold opening stroke ①	mm	3200/2200										
	Mold height min.	mm	1000										
	Mold height max.	mm	2000										
	Total daylight max.	mm	4200										
	Dist. between tie-bars (H×V)	mm	2270×1900										
	Ejector stroke	mm	550										
	Ejector force	kN	580										
	Mold weight max. ②	t	75										
				22500				32500			40500		50500
		A	B	C	D	A	B	A	B	B	B		
INJECTION UNIT	Screw diameter	mm	140	150	160	170	160	170	170	185	200	220	
	Screw L/D ratio	L/D	24	22.4	21	19.8	24	22.6	23.5	21.6	20	20.5	
	Injection volume (theoretical)	cm ³	10467	12016	13672	15434	17492	19747	23378	27686	35185	45615	
	Injection weight (PS)	g	9525	10935	12441	14045	15918	17970	21274	25194	32019	41510	
	Injection rate (PS) ③	g/s	1352	1552	1766	1994	1559	1761	1576	1867	2386	2617	
	Injection pressure	MPa	185	161	141	125	160	142	159	134	132	120	
	Injection pressure (max)	MPa	211	184	161	143	180	159	179	151	147	135	
	Plasticizing rate (GPPS) ④	g/s	155.0	176.0	196.0	222.0	\	\	\	\	\	\	
	Plasticizing rate (HDPE) ⑤	g/s	243.0	294.0	303.0	334.0	280.0	310.0	309.0	320.0	380.0	370.0	
Screw speed	rpm	94				81			70		70	53	
OTHERS	Pump motor power	kW	205				205			205		255	255
	Heater power	kW	137				189			211		211	228
	Machine dimension (L×W×H) ⑥	m	14.27×5.79×4.43				15.22×5.79×4.43			16.05×5.79×4.43		16.37×5.79×4.43	17.41×5.79×4.43
	Machine weight	t	164				167			174		179	183
	Hopper capacity (OP)	kg	400				400			400		400	400
	Oil tank ⑦	l	1670				1670			1670		2800	2800

NOTE:

- ① With min. mold height / with max. mold height.
- ② Moving platen: 2/3 of max. mold weight.
- ③ The injection rate refers to the parameter in the differential injection condition.
- ④ Plasticizing capacity (GPPS): GB standard, with application of GPPS plasticizing capacity of 3-zone screws.
- ⑤ Plasticizing capacity (HDPE): Euromap 19, with application of HDPE plasticizing capacity of barrier screws.
- ⑥ The size is the net size of the machine, excluding the width of the feeding platform and the working platform.
- ⑦ The oil tank volume refers to the volume of the oil tank itself, excluding the volume in cylinder and pipeline. In this sense, the customer is advised to prepare the hydraulic oil according to 1.35 times of the oil tank volume.

The above plasticizing capacity is for reference only.

We reserve the right to make changes as a result of further technical advantages.



DIMENSIONS JU33000 V

CLAMPING UNIT

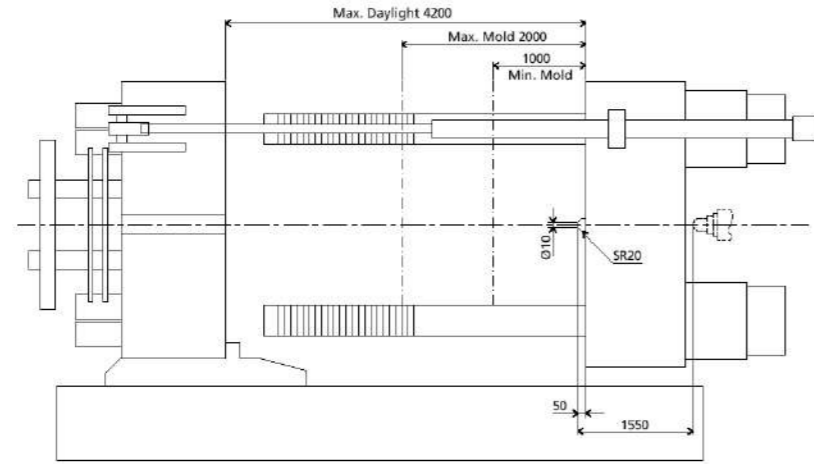

FRONT VIEW

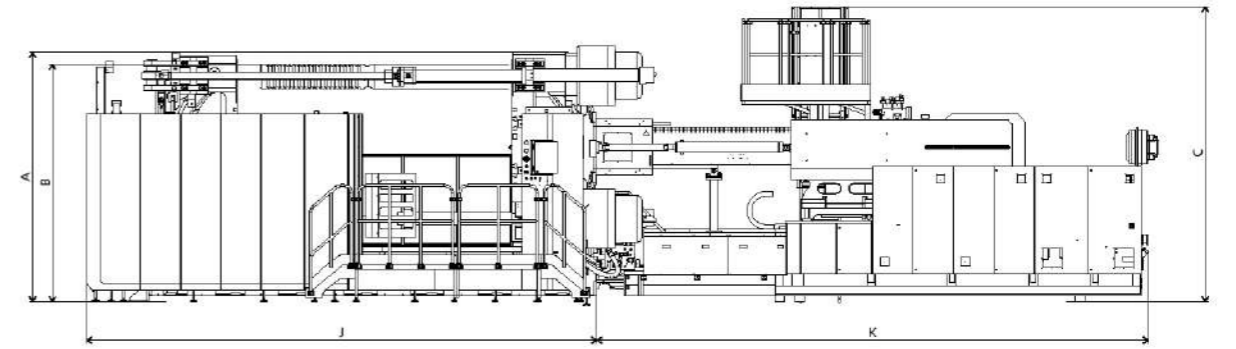

FIXED PLATEN DIMENSIONS

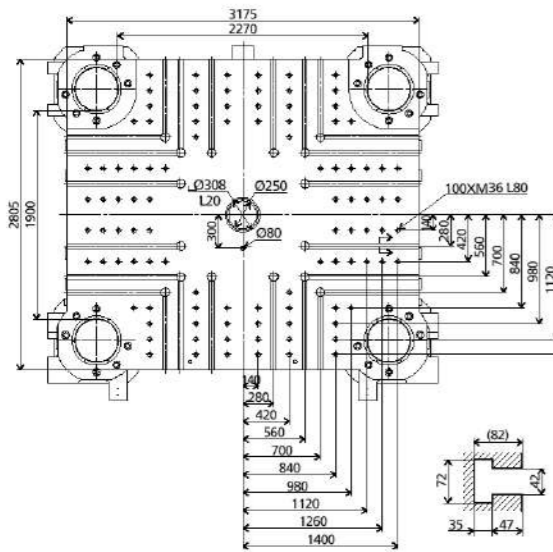

MOVING PLATEN DIMENSIONS

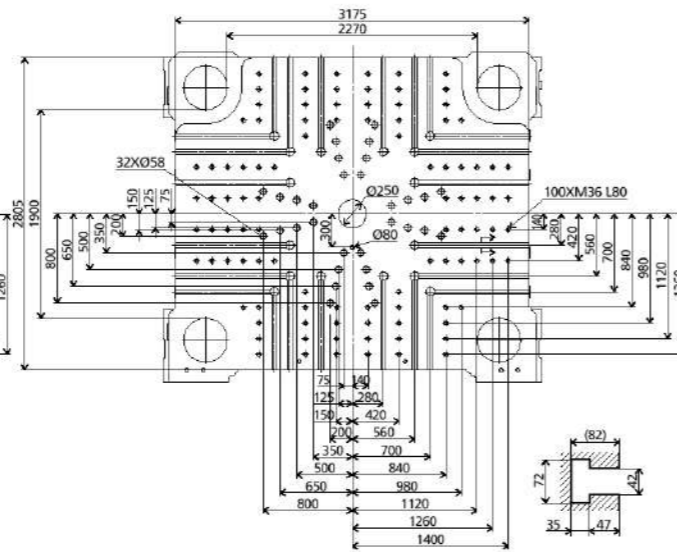

TOP VIEW

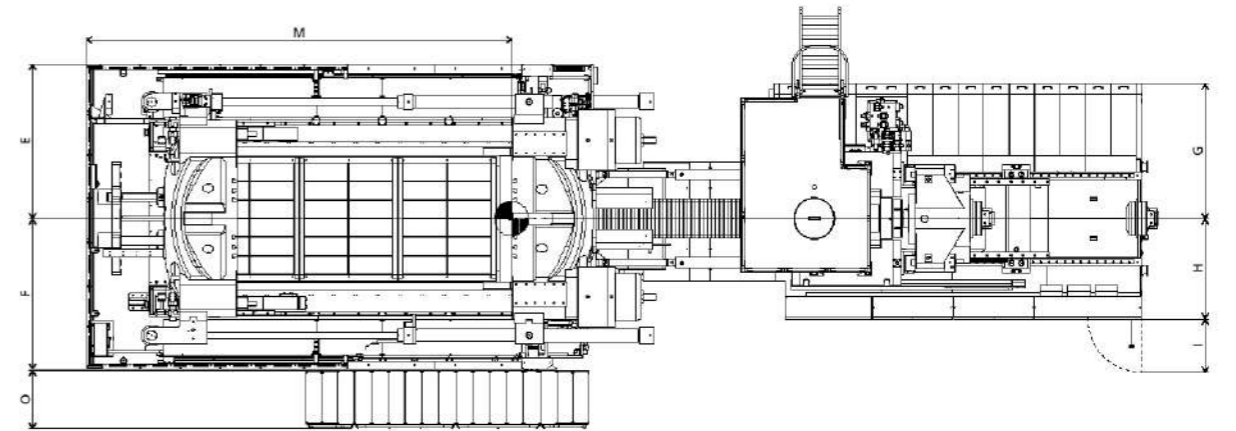

ROBOT MECHANICAL INTERFACE

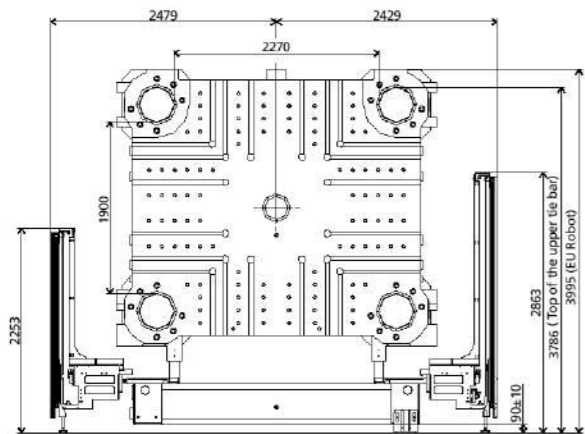

ROBOTTOP VIEW FIXED PLATEN

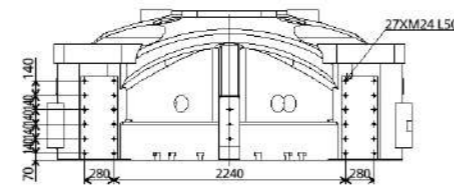

SIDE VIEW

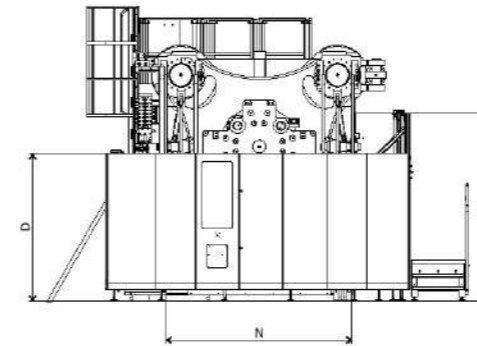

STANDARD

	INJECTION UNIT										DIMENSIONS (mm)				
	A	B	C	D	E	F	G	H	I	J	K	L	M	N	O
22500	3995	3786	4421	2202	2479	2429	1935	1422	796	8075	6260	2812	6705	3126	864
32500	3995	3786	4421	2202	2479	2429	1935	1422	796	8075	7278	2812	6705	3126	864
40500	3995	3786	4421	2202	2479	2429	1965	1452	796	8075	7866	2812	6705	3126	864
50500	3995	3786	4421	2202	2479	2429	2010	1497	796	8075	8378	2812	6705	3126	864
62500	3995	3786	4421	2202	2479	2429	2010	1497	796	8075	8678	2812	6705	3126	864



JU40000 V

MACHINE TYPE		JU40000 V		
CLAMPING UNIT	Clamping force	kN	40000	
	Mold opening stroke ①	mm	3460/2260	
	Mold height min.	mm	1000	
	Mold height max.	mm	2200	
	Total daylight max.	mm	4460	
	Dist. between tie-bars (H×V)	mm	2400×2000	
	Ejector stroke	mm	550	
	Ejector force	kN	580	
	Mold weight max. ②	t	86	
		93500	106500	
		B	B	
INJECTION UNIT	Screw diameter	mm	240	260
	Screw L/D ratio	L/D	23	23
	Injection volume (theoretical)	cm ³	60167	80170
	Injection weight (PS)	g	54752	72954
	Injection rate (PS) ③	g/s	3188	3741
	Injection pressure	MPa	141	120
	Injection pressure (max)	MPa	155	132
	Plasticizing rate (GPPS) ④	g/s	\	\
	Plasticizing rate (HDPE) ⑤	g/s	470.0	500.0
Screw speed	rpm	50	42	
OTHERS	Pump motor power	kW	360	360
	Heater power	kW	297	321
	Machine dimension (L×W×H) ⑥	m	19.70×5.92×4.50	20.25×5.92×4.50
	Machine weight	t	225	230
	Hopper capacity (OP)	kg	600	600
Oil tank ⑦	l	3150	3150	

NOTE:

- ① With min. mold height / with max. mold height.
 ② Moving platen: 2/3 of max. mold weight.
 ③ The injection rate refers to the parameter in the differential injection condition.
 ④ Plasticizing capacity (GPPS): GB standard, with application of GPPS plasticizing capacity of 3-zone screws.
 ⑤ Plasticizing capacity (HDPE): Euromap 19, with application of HDPE plasticizing capacity of barrier screws.
 ⑥ The size is the net size of the machine, excluding the width of the feeding platform and the working platform.
 ⑦ The oil tank volume refers to the volume of the oil tank itself, excluding the volume in cylinder and pipeline. In this sense, the customer is advised to prepare the hydraulic oil according to 1.35 times of the oil tank volume.

The above plasticizing capacity is for reference only.

We reserve the right to make changes as a result of further technical advantages.

DIMENSIONS JU40000 V

CLAMPING UNIT

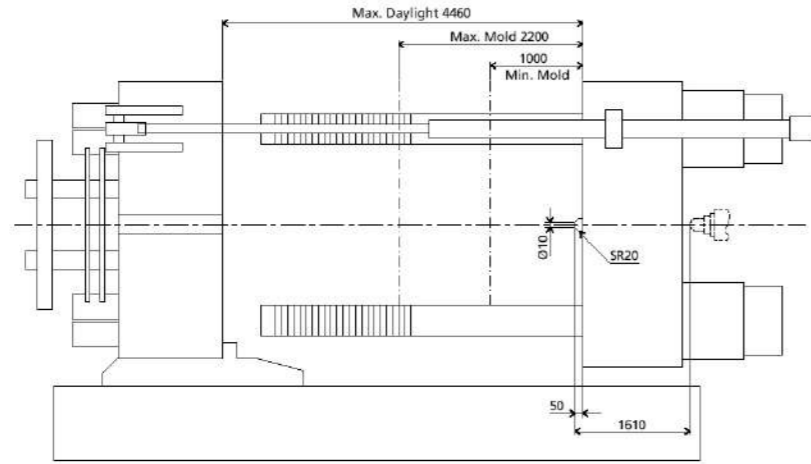

FRONT VIEW

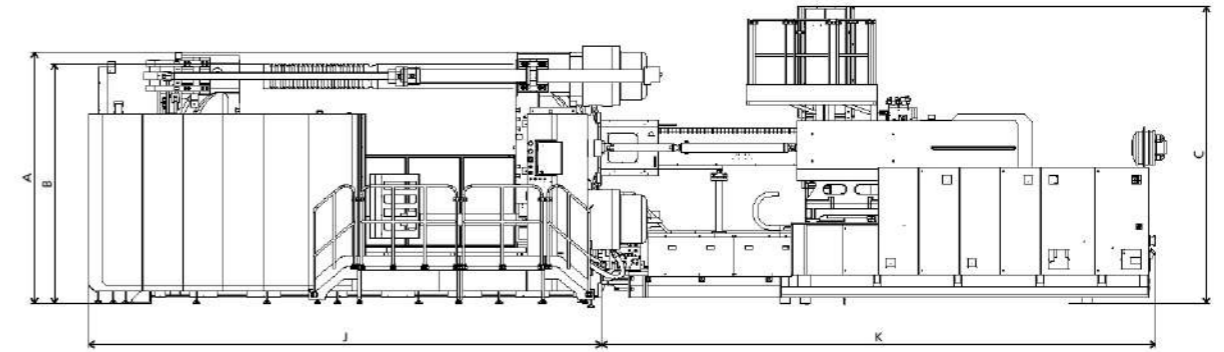

FIXED PLATEN DIMENSIONS

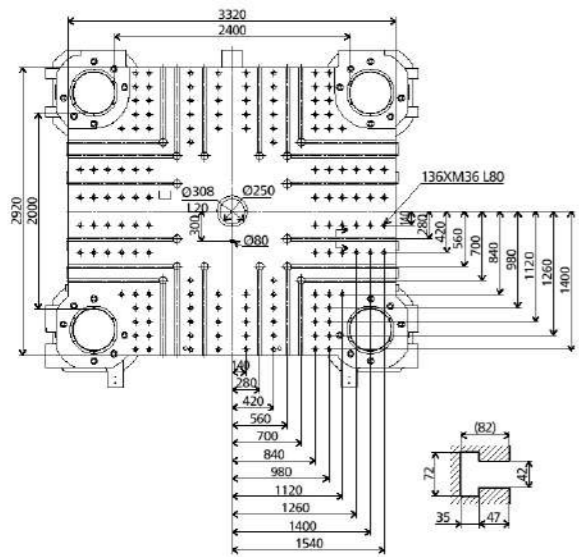

MOVING PLATEN DIMENSIONS

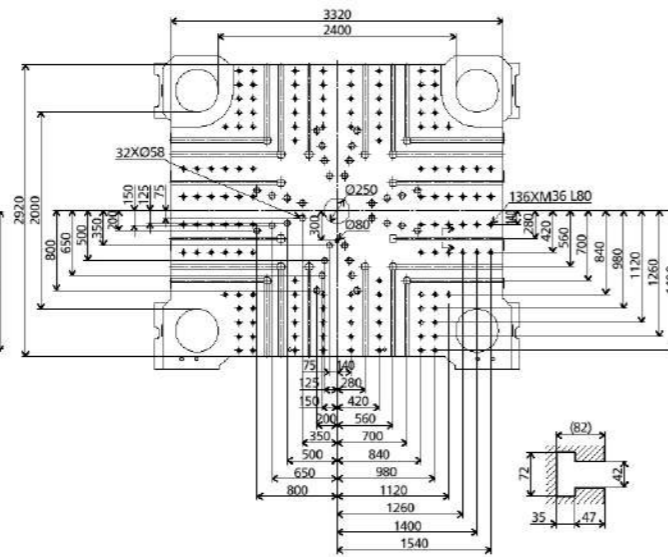

TOP VIEW

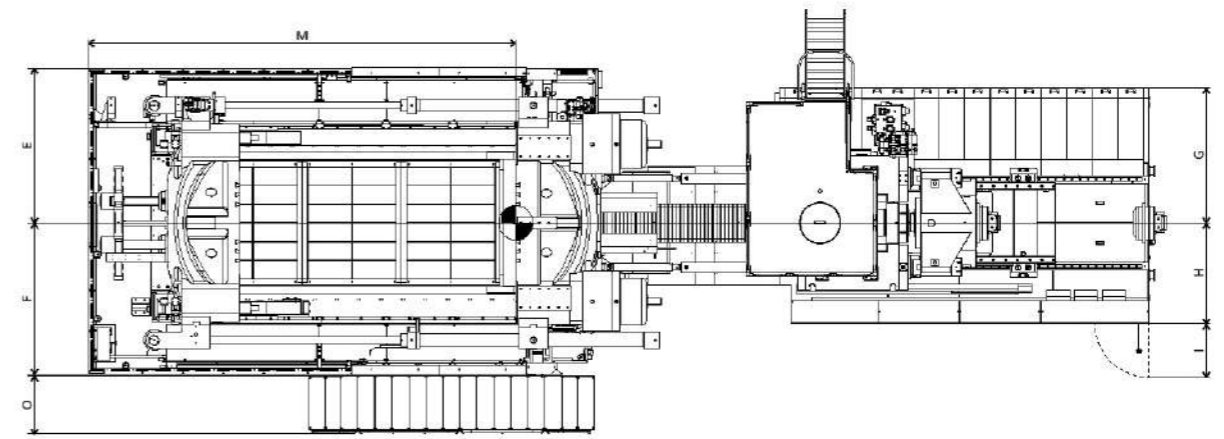

ROBOT MECHANICAL INTERFACE

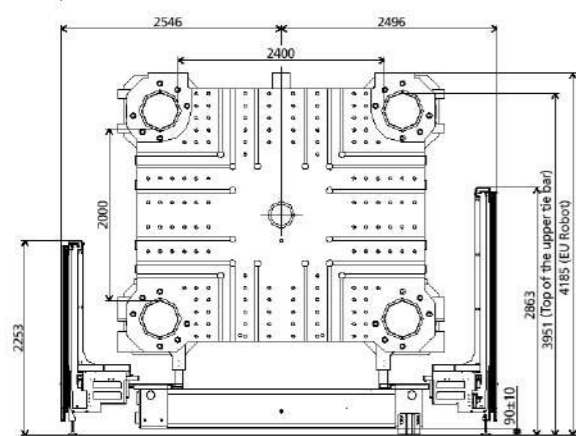

ROBOTTOP VIEW FIXED PLATEN

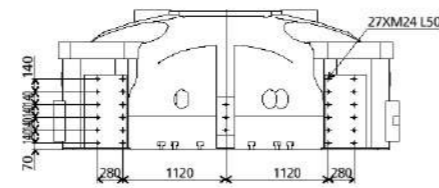

SIDE VIEW

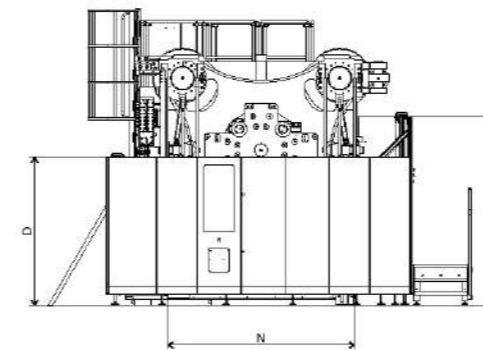

STANDARD

	INJECTION UNIT										DIMENSIONS (mm)				
	A	B	C	D	E	F	G	H	I	J	K	L	M	N	O
93500	4185	3951	4492	2202	2546	2496	2085	1562	796	8511	10092	2812	7051	3260	864
106500	4185	3951	4492	2202	2546	2496	2085	1562	796	8511	10742	2812	7051	3260	864



JU55000 V

MACHINE TYPE		JU55000 V		
CLAMPING UNIT	Clamping force	kN	55000	
	Mold opening stroke ①	mm	4700/3500	
	Mold height min.	mm	1300	
	Mold height max.	mm	2500	
	Total daylight max.	mm	6000	
	Dist. between tie-bars (H×V)	mm	2600×2600	
	Ejector stroke	mm	600	
	Ejector force	kN	800	
	Mold weight max. ②	t	130	
		93500	106500	
		B	B	
INJECTION UNIT	Screw diameter	mm	240	260
	Screw L/D ratio	L/D	23	23
	Injection volume (theoretical)	cm ³	60167	80170
	Injection weight (PS)	g	54752	72954
	Injection rate (PS) ③	g/s	3188	3741
	Injection pressure	MPa	141	120
	Injection pressure (max)	MPa	155	132
	Plasticizing rate (GPPS) ④	g/s	\	\
	Plasticizing rate (HDPE) ⑤	g/s	470.0	500.0
Screw speed	rpm	50	42	
OTHERS	Pump motor power	kW	360	360
	Heater power	kW	297	321
	Machine dimension (L×W×H) ⑥	m	21.46×6.55×5.07	22.01×6.55×5.07
	Machine weight	t	365	370
	Hopper capacity (OP)	kg	600	600
Oil tank ⑦	l	3150	3150	

NOTE:

- ① With min. mold height / with max. mold height.
 ② Moving platen: 2/3 of max. mold weight.
 ③ The injection rate refers to the parameter in the differential injection condition.
 ④ Plasticizing capacity (GPPS): GB standard, with application of GPPS plasticizing capacity of 3-zone screws.
 ⑤ Plasticizing capacity (HDPE): Euromap 19, with application of HDPE plasticizing capacity of barrier screws.
 ⑥ The size is the net size of the machine, excluding the width of the feeding platform and the working platform.
 ⑦ The oil tank volume refers to the volume of the oil tank itself, excluding the volume in cylinder and pipeline. In this sense, the customer is advised to prepare the hydraulic oil according to 1.35 times of the oil tank volume.

The above plasticizing capacity is for reference only.

We reserve the right to make changes as a result of further technical advantages.

CLAMPING UNIT

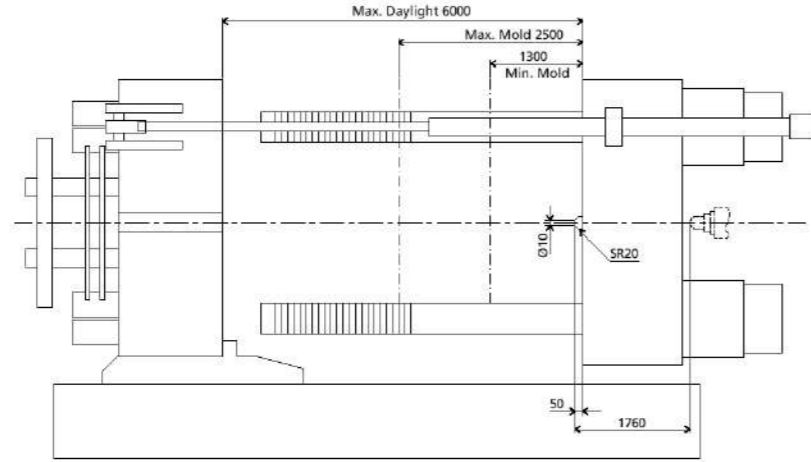

FRONT VIEW

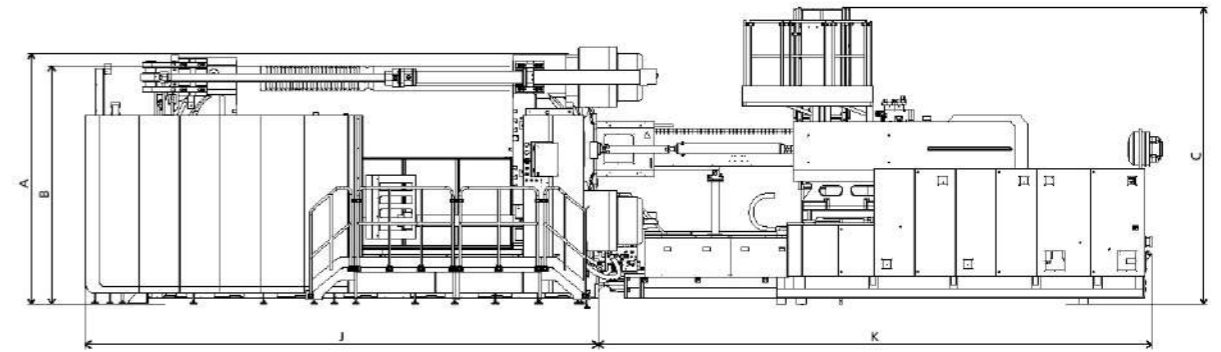

FIXED PLATEN DIMENSIONS

MOVING PLATEN DIMENSIONS

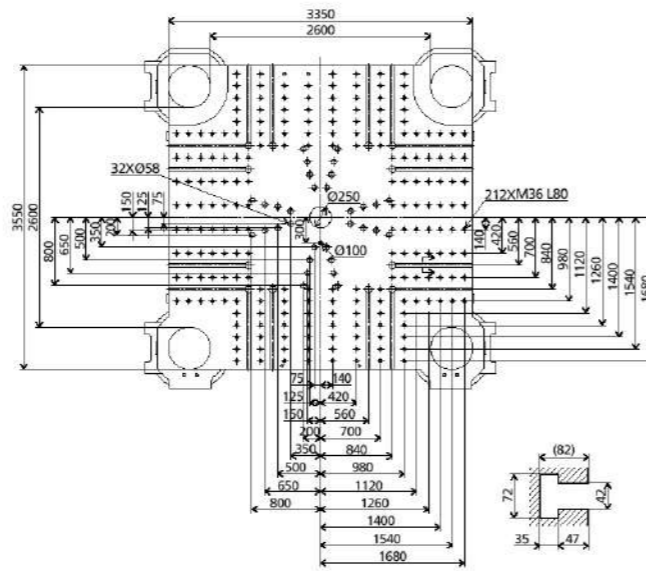
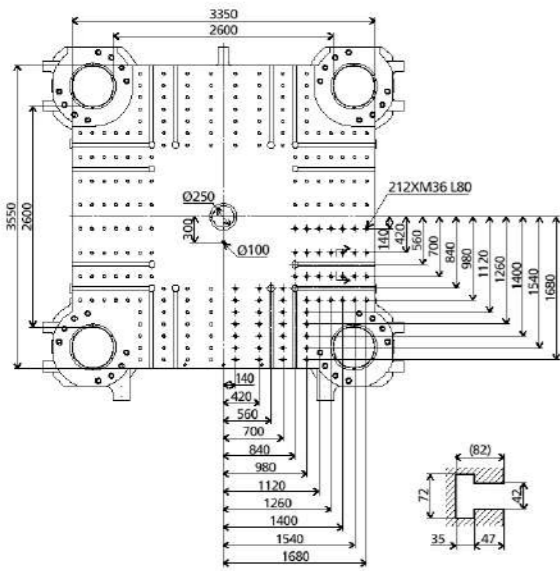

TOP VIEW

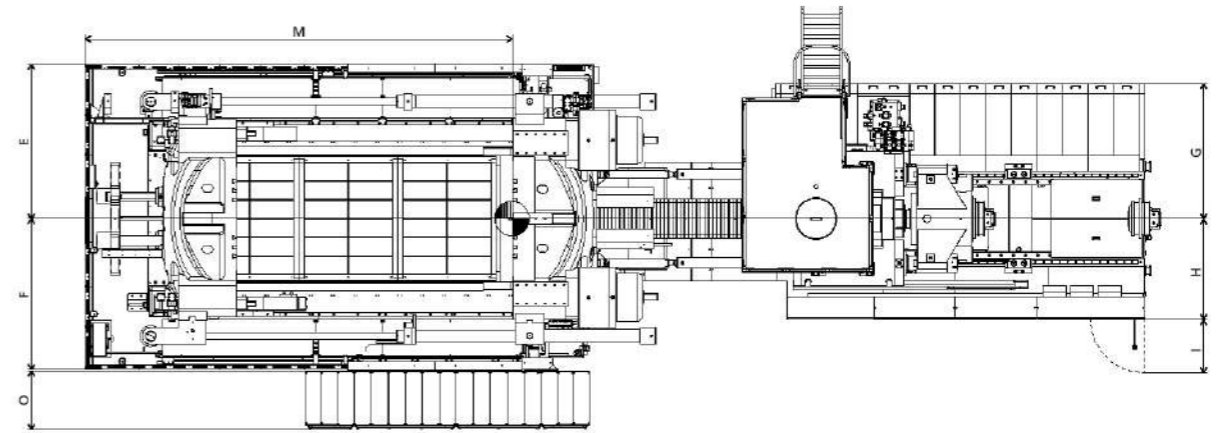

ROBOT MECHANICAL INTERFACE

ROBOTOP VIEW FIXED PLATEN

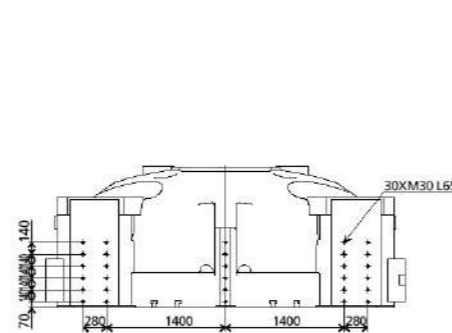
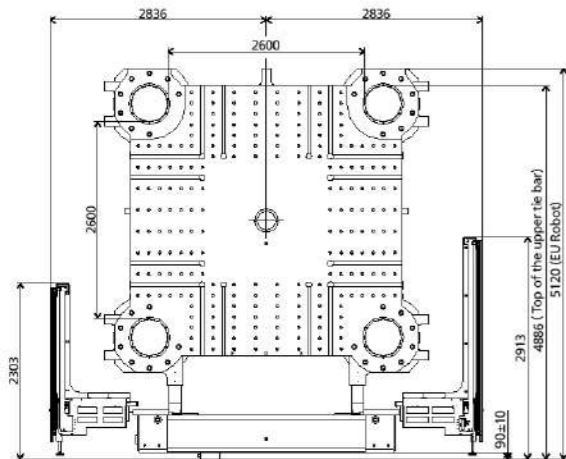

SIDE VIEW

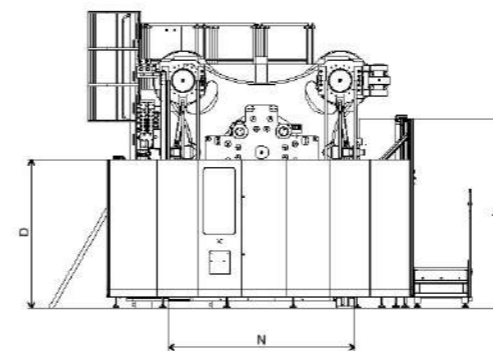

STANDARD

	INJECTION UNIT										DIMENSIONS (mm)				
	A	B	C	D	E	F	G	H	I	J	K	L	M	N	O
93500	5120	4886	5067	2252	2836	2836	2085	1562	796	10413	10192	2862	8812	3340	864
106500	5120	4886	5067	2252	2836	2836	2085	1562	796	10413	10592	2862	8812	3340	864

JU66000 V

MACHINE TYPE		JU66000 V		
CLAMPING UNIT	Clamping force	kN	66000	
	Mold opening stroke ①	mm	5200/3200	
	Mold height min.	mm	1500	
	Mold height max.	mm	3500	
	Total daylight max.	mm	6700	
	Dist. between tie-bars (H×V)	mm	3200×2600	
	Ejector stroke	mm	1000	
	Ejector force	kN	810	
	Mold weight max. ②	t	180	
		202500		
		A	B	
INJECTION UNIT	Screw diameter	mm	285	300
	Screw L/D ratio	L/D	24	24
	Injection volume (theoretical)	cm ³	121208	134303
	Injection weight (PS)	g	110299	122215
	Injection rate (PS) ③	g/s	3196	3541
	Injection pressure	MPa	\	\
	Injection pressure (max)	MPa	176	158
	Plasticizing rate (GPPS) ④	g/s	\	\
	Plasticizing rate (HDPE) ⑤	g/s	450.0	485.0
Screw speed	rpm	28		
OTHERS	Pump motor power	kW	450	
	Heater power	kW	450	480
	Machine dimension (L×W×H) ⑥	m	25×7.3×6.8	25×7.3×6.8
	Machine weight	t	500	500
	Hopper capacity (OP)	kg	600	600
	Oil tank ⑦	l	5000	5000

NOTE:

- ① With min. mold height / with max. mold height.
 ② Moving platen: 2/3 of max. mold weight.
 ③ The injection rate refers to the parameter in the differential injection condition.
 ④ Plasticizing capacity (GPPS): GB standard, with application of GPPS plasticizing capacity of 3-zone screws.
 ⑤ Plasticizing capacity (HDPE): Euromap 19, with application of HDPE plasticizing capacity of barrier screws.
 ⑥ The size is the net size of the machine, excluding the width of the feeding platform and the working platform.
 ⑦ The oil tank volume refers to the volume of the oil tank itself, excluding the volume in cylinder and pipeline. In this sense, the customer is advised to prepare the hydraulic oil according to 1.35 times of the oil tank volume.

The above plasticizing capacity is for reference only.

We reserve the right to make changes as a result of further technical advantages.

JU88000 V

MACHINE TYPE		JU88000 V		
CLAMPING UNIT	Clamping force	kN	88000	
	Mold opening stroke ①	mm	5300/3500	
	Mold height min.	mm	1700	
	Mold height max.	mm	3500	
	Total daylight max.	mm	7000	
	Dist. between tie-bars (H×V)	mm	3400×2820	
	Ejector stroke	mm	1000	
	Ejector force	kN	1000	
	Mold weight max. ②	kN	180	
		202500		
		B		
INJECTION UNIT	Screw diameter	mm	300	
	Screw L/D ratio	L/D	24	
	Injection volume (theoretical)	cm ³	134303	
	Injection weight (PS)	g	122215	
	Injection rate (PS) ③	g/s	3541	
	Injection pressure	MPa	\	
	Injection pressure (max)	MPa	158	
	Plasticizing rate (GPPS) ④	g/s	\	
	Plasticizing rate (HDPE) ⑤	g/s	485.0	
Screw speed	rpm	28		
OTHERS	Pump motor power	kW	450	
	Heater power	kW	480	480
	Machine dimension (L×W×H) ⑥	m	28×9.5×6.8	28×9.5×6.8
	Machine weight	t	610	610
	Hopper capacity (OP)	kg	600	600
	Oil tank ⑦	l	5500	5500

NOTE:

- ① With min. mold height / with max. mold height.
 ② Moving platen: 2/3 of max. mold weight.
 ③ The injection rate refers to the parameter in the differential injection condition.
 ④ Plasticizing capacity (GPPS): GB standard, with application of GPPS plasticizing capacity of 3-zone screws.
 ⑤ Plasticizing capacity (HDPE): Euromap 19, with application of HDPE plasticizing capacity of barrier screws.
 ⑥ The size is the net size of the machine, excluding the width of the feeding platform and the working platform.
 ⑦ The oil tank volume refers to the volume of the oil tank itself, excluding the volume in cylinder and pipeline. In this sense, the customer is advised to prepare the hydraulic oil according to 1.35 times of the oil tank volume.

The above plasticizing capacity is for reference only.

We reserve the right to make changes as a result of further technical advantages.