

TECHNOLOGY TO THE POINT



NINGBO ZHAFIR PLASTICS MACHINERY MANUFACTURING CO., LTD.
No. 98 Guanhai Road, Chunxiao, Beilun, Ningbo, China 315800

Tel. +86-574-86182986
Fax. +86-574-86182977
E-Mail: contact@mail.zhafir.cn
www.zhafir.cn



ZERES SERIES

TECHNICAL SPECIFICATION

5,500 – 13,800 kN

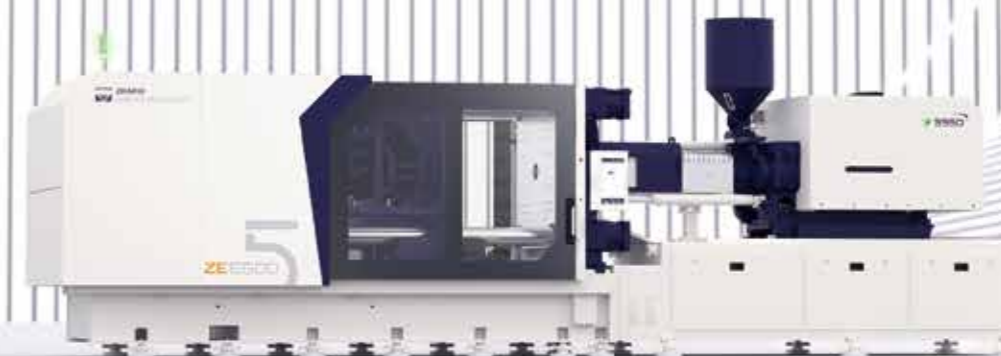

TECHNICAL DATA ZE5500 V

		CLAMPING UNIT											
Clamping force	kN	5500											
Mold opening stroke	mm	900											
Mold height min.	mm	400											
Mold height max.	mm	880											
Total daylight max.	mm	1780											
Dist. Between tie-bars (H×V)	mm	970×970											
Size of mold platen (H×V)	mm	1320×1320											
Mold dimension min.	mm	630×630											
Ejector stroke	mm	180											
Ejector force	kN	154											
		A	B	C	A	B	C	A	B	C	A	B	C
Screw diameter	mm	55	60	65	60	65	70	65	70	80	75	80	90
Screw L/D ratio	L/D	21.8	20	18.5	21.6	20	18.6	21.5	20	17.5	21.3	20	17.8
Injection volume (theoretical) ¹	cm ³	617	735	862	791	929	1077	1068	1239	1618	1634	1859	2353
Injection weight (PS) ²	g	562	668	785	720	845	980	972	1127	1472	1487	1692	2141
Injection pressure ³	MPa	214	180	153	210	180	155	210	180	138	205	180	142
	bar	2140	1800	1530	2100	1800	1550	2100	1800	1380	2050	1800	1420
Holding pressure ³	MPa	190	160	136	187	160	138	190	162	124	185	162	128
	bar	1900	1600	1360	1870	1600	1380	1900	1620	1240	1850	1620	1280
Screw speed	rpm	300			260			240			220		
Plasticizing rate (GPPS) ⁴	g/s	54	64	71	57	68	72	62	71	88	70	92	105
Plasticizing rate (HDPE) ⁵	g/s	-	-	-	-	-	-	93	111	132	105	141	165
Nozzle contact force	kN	85			85			85			85		
INJECTION UNIT		1400			1700			2250			3350		
Injection speed	mm/s	160			160			160			160		
Injection rate (PS)	g/s	332	395	463	395	463	537	463	537	702	617	702	889
INJECTION UNIT		1400h			1700h			2250h			-		
Injection speed	mm/s	250			250			250			-		
Injection rate (PS)	g/s	518	617	724	617	724	840	723	839	1097	-	-	-
INJECTION UNIT		1400hs			1700hs			-			-		
Injection speed	mm/s	350			350			-			-		
Injection rate (PS)	g/s	726	864	1014	864	1014	1176	-	-	-	-	-	-
Connection power	kW/A	1400:52/87			1700:58/98			2250:65/109			83/138		
		1400h:65/109			1700h:74/125			2250h:89/150					
Heating power	kW	29.3			33.1			36.1			42.6		
Machine dimension	m	8.48×2.29×2.50			8.62×2.29×2.50			8.48×2.29×2.50			8.74×2.29×2.50		
Machine weight	t	26.27			26.97			28.55			28.64		
Hopper capacity	l	50			50			50			100		
Pressure	MPa	17.5			17.5			17.5			17.5		
Flow	l/min	204			204			204			204		
Oil tank	l	284			284			284			284		

NOTE: ¹ Shot volume is the theoretical value which equals to cross section area of screw cylinder or barrel plunger × screw stroke.

² Shot weight (PS) is the theoretical value of shot volume melt density of PS. It is not a measured value.

³ Injection & holding pressure are theoretical values of machine output, not the actual resin pressure.

⁴ Plasticizing capacity(GPPS):GB standard,with application of GPPS plasticizing capacity of 3-zone screws.

⁵ Plasticizing capacity(HDPE):Euromap 19,with application of HDPE plasticizing capacity of barrier screws.

This parameter table is based on machine standard configuration;
We reserve the right to make changes as a result of further technical advances.

MACHINE DIMENSIONS

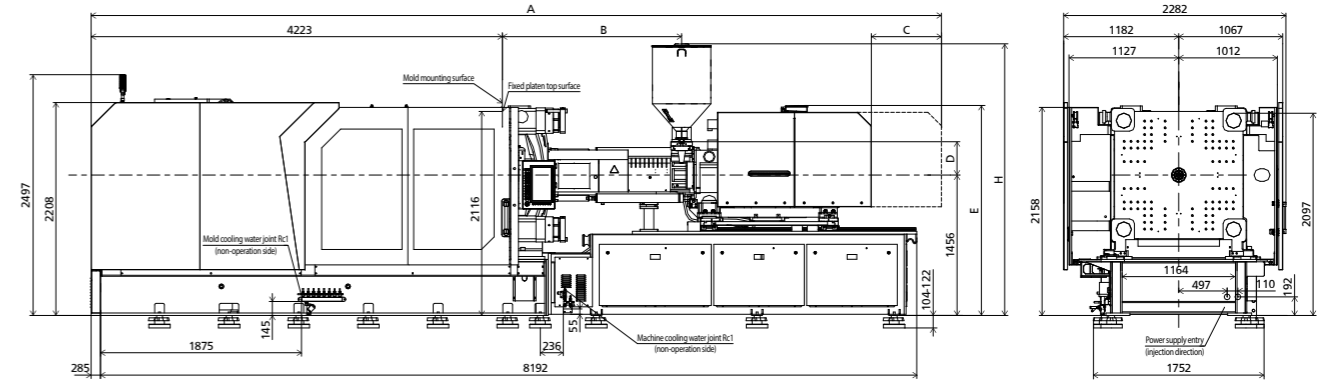

	A	B	C	D	E	F	G	H	I	J	K	L	M	N
1400,1400h,1400hs	8176	1383	560	245	2167	4XM10 L20	115	2304	143	82	115	204	Ø3	SR10
1700,1700h,1700hs	8619	1543	560	250	2259	4XM10 L20	115	2309	148	95	115	222.5	Ø3	SR10
2250,2250h	8353	1630	610	327	2107	4XM10 L20	115	2470	225	95	115	67	Ø4	SR15
3350	8732	1841	720	346	2107	4XM12 L25	170	2796	225	100	170	128	Ø4	SR15

PLATEN DIMENSIONS

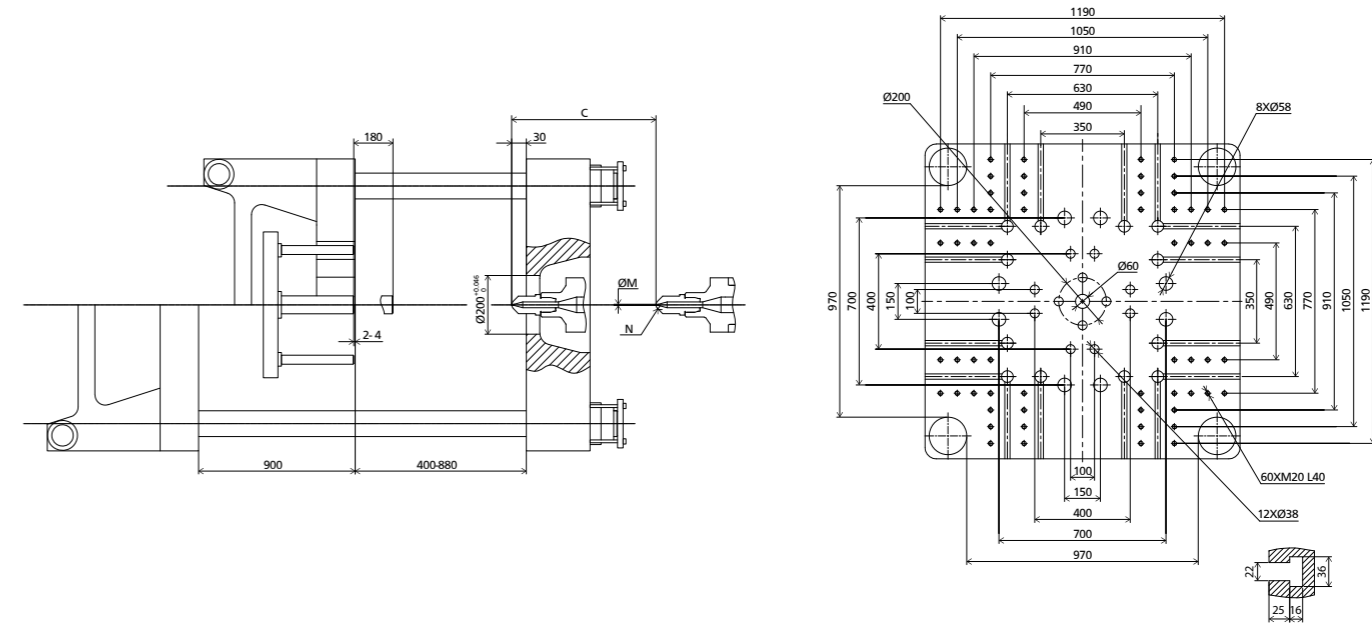

OTHERS DIMENSIONS

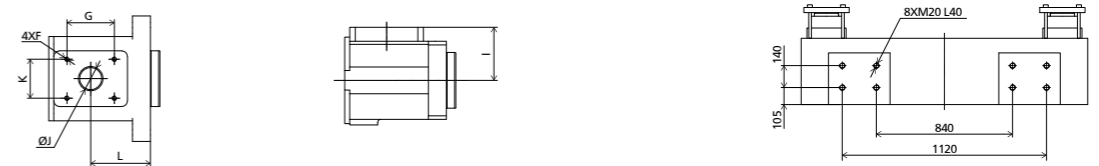

HOPPER MOUNTING DIMENSION

ROBOT TOP VIEW FIXED PLATEN

TECHNICAL DATA ZE8000 V

CLAMPING UNIT													
Clamping force	kN	8000											
Mold opening stroke	mm	1000											
Mold height min.	mm	420											
Mold height max.	mm	1000											
Total daylight max.	mm	2000											
Dist. Between tie-bars (H×V)	mm	1080×1080											
Size of mold platen (H×V)	mm	1480×1480											
Mold dimension min.	mm	700×700											
Ejector stroke	mm	200											
Ejector force	kN	196											
		A	B	C	A	B	C	A	B	C	A	B	C
Screw diameter	mm	60	65	70	65	70	80	75	80	90	80	90	100
Screw L/D ratio	L/D	21.6	20	18.6	21.5	20	17.5	21.3	20	17.8	24.8	22	19.8
Injection volume (theoretical) ¹	cm ³	791	929	1077	1068	1239	1618	1634	1859	2353	2261	2862	3534
Injection weight (PS) ²	g	720	845	980	972	1127	1472	1487	1692	2141	2058	2605	3216
Injection pressure ³	MPa	210	180	155	210	180	138	205	180	142	227	180	145
	bar	2100	1800	1550	2100	1800	1380	2050	1800	1420	2270	1800	1450
Holding pressure ³	MPa	187	160	138	190	162	124	185	162	128	204	162	131
	bar	1870	1600	1380	1900	1620	1240	1850	1620	1280	2040	1620	1310
Screw speed	rpm	260			240			220			190		
Plasticizing rate (GPPS) ⁴	g/s	57	68	72	62	71	88	70	92	105	85	107	131
Plasticizing rate (HDPE) ⁵	g/s	-	-	-	93	111	132	105	141	165	128	162	200
Nozzle contact force	kN	85			85			85			85		
INJECTION UNIT		1700			2250			3350			5200		
Injection speed	mm/s	160			160			160			160		
Injection rate (PS)	g/s	395	463	537	463	537	702	617	702	889	702	889	1097
INJECTION UNIT		1700h			2250h			-			-		
Injection speed	mm/s	250			250			-			-		
Injection rate (PS)	g/s	617	724	840	723	839	1097	-	-	-	-	-	-
INJECTION UNIT		1700hs			-			-			-		
Injection speed	mm/s	350			-			-			-		
Injection rate (PS)	g/s	864	1014	1176	-	-	-	-	-	-	-	-	-
Connection power	kW/A	1700:58/98			2250:65/109			83/138			98/164		
		1700h:74/125			2250h:89/150								
		1700hs:83/139											
Heating power	kW	33.1			36.1			42.6			54.3		
Machine dimension	m	9.70×2.44×2.70			9.70×2.44×2.70			9.70×2.44×2.70			9.81×2.44×2.70		
Machine weight	t	36.25			37.80			37.90			38.90		
Hopper capacity	l	50			50			100			100		
Pressure	MPa	17.5			17.5			17.5			17.5		
Flow	l/min	252			252			252			252		
Oil tank	l	353			353			353			353		

NOTE: ¹ Shot volume is the theoretical value which equals to cross section area of screw cylinder or barrel plunger × screw stroke.

² Shot weight (PS) is the theoretical value of shot volume melt density of PS. It is not a measured value.

³ Injection & holding pressure are theoretical values of machine output, not the actual resin pressure.

⁴ Plasticizing capacity(GPPS):GB standard, with application of GPPS plasticizing capacity of 3-zone screws.

⁵ Plasticizing capacity(HDPE):Euromap 19, with application of HDPE plasticizing capacity of barrier screws.

This parameter table is based on machine standard configuration;
We reserve the right to make changes as a result of further technical advances.

MACHINE DIMENSIONS

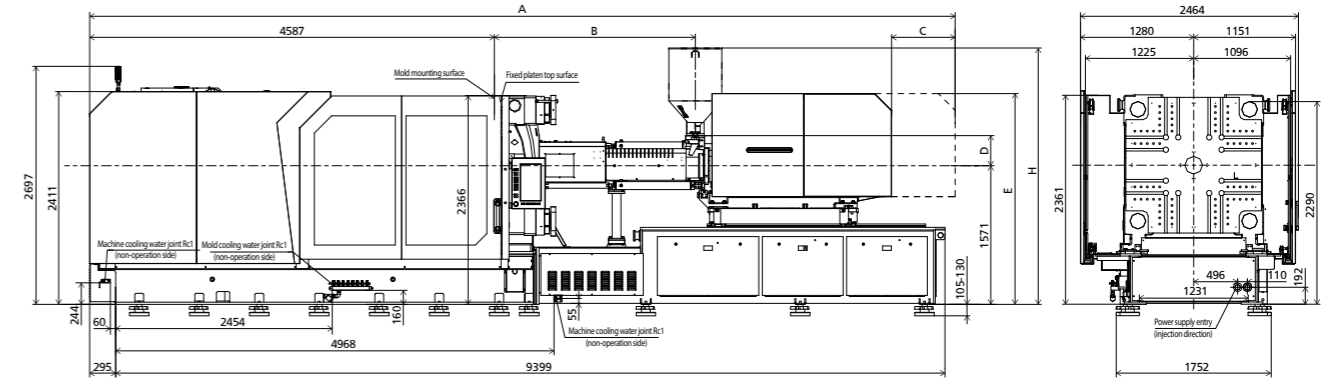

	A	B	C	D	E	F	G	H	I	J	K	L	M	N
1700,1700h,1700hs	8983	1543	560	250	2374	4XM10 L20	115	2424	148	95	115	222.5	Ø3	SR10
2250,2250h	8717	1630	610	327	2222	4XM10 L20	115	2585	225	95	115	67	Ø4	SR15
3350	9096	1841	720	346	2222	4XM12 L25	170	2911	225	100	170	128	Ø4	SR15
5200	9808	2278	720	356	2388	4XM12 L20	170	2905	220	100	170	105	Ø4	SR15

PLATEN DIMENSIONS

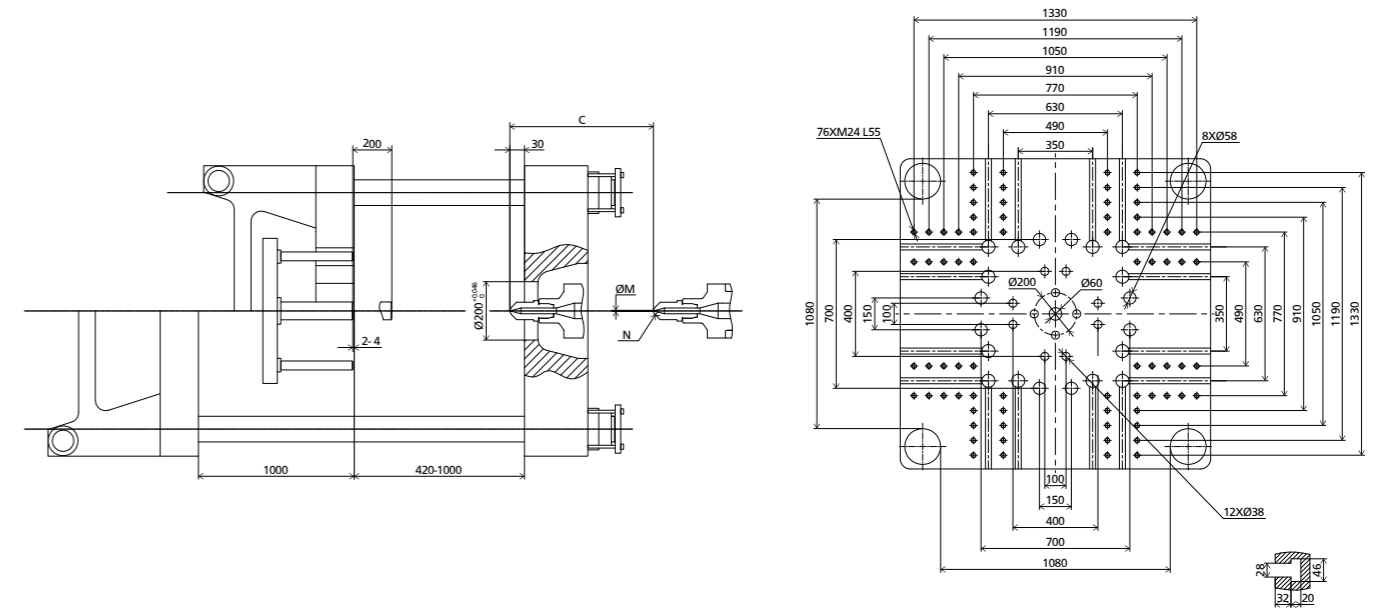

OTHERS DIMENSIONS

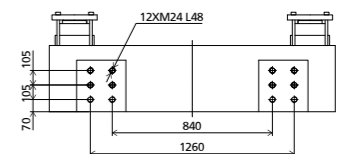
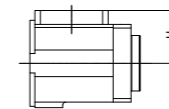
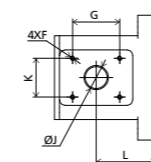

HOPPER MOUNTING DIMENSION

ROBOT TOP VIEW FIXED PLATEN

TECHNICAL DATA ZE8500 V

CLAMPING UNIT														
Clamping force	kN	8500												
Mold opening stroke	mm	1200												
Mold height min.	mm	450												
Mold height max.	mm	1100												
Total daylight max.	mm	2300												
Dist. Between tie-bars (H×V)	mm	1160×1160												
Size of mold platen (H×V)	mm	1550×1550												
Mold dimension min.	mm	770×770												
Ejector stroke	mm	200												
Ejector force	kN	230												
		A	B	C	A	B	C	A	B	C	A	B	C	
Screw diameter	mm	65	70	80	75	80	90	80	90	100	90	100	110	
Screw L/D ratio	L/D	21.5	20	17.5	21.3	20	17.8	24.8	22	19.8	24.4	22	20	
Injection volume (theoretical) ¹	cm ³	1068	1239	1618	1634	1859	2353	2261	2862	3534	2989	3691	4466	
Injection weight (PS) ²	g	972	1127	1472	1487	1692	2141	2058	2605	3216	2720	3359	4064	
Injection pressure ³	MPa	210	180	138	205	180	142	227	180	145	222	180	149	
	bar	2100	1800	1380	2050	1800	1420	2270	1800	1450	2220	1800	1490	
Holding pressure ³	MPa	190	162	124	185	162	128	204	162	131	200	162	133	
	bar	1900	1620	1240	1850	1620	1280	2040	1620	1310	2000	1620	1330	
Screw speed	rpm	240			220			190			170			
Plasticizing rate (GPPS) ⁴	g/s	62	71	88	70	92	105	85	107	131	103	127	150	
Plasticizing rate (HDPE) ⁵	g/s	93	111	132	105	141	165	128	162	200	156	191	228	
Nozzle contact force	kN	85			85			85			85			
INJECTION UNIT		2250			3350			5200			6700			
Injection speed	mm/s	160			160			160			150			
Injection rate (PS)	g/s	463	537	702	617	702	889	702	889	1097	833	1029	1245	
INJECTION UNIT		2250h			-			-			-			
Injection speed	mm/s	250			-			-			-			
Injection rate (PS)	g/s	723	839	1097	-	-	-	-	-	-	-	-	-	
OTHERS	Connection power	kW/A	2250:65/109 2250h:89/150			83/138			98/164			126/211		
	Heating power	kW	36.1			42.6			54.3			75.6		
	Machine dimension	m	11.17×2.49×2.67			11.17×2.49×2.67			11.17×2.49×2.67			11.17×2.49×2.67		
	Machine weight	t	49.20			49.30			50.20			50.30		
	Hopper capacity	l	50			100			100			100		
	Pressure	MPa	21			21			21			21		
	Flow	l/min	248			248			248			248		
Oil tank	l	411			411			411			411			

NOTE: ¹ Shot volume is the theoretical value which equals to cross section area of screw cylinder or barrel plunger × screw stroke.
² Shot weight (PS) is the theoretical value of shot volume melt density of PS. It is not a measured value.
³ Injection & holding pressure are theoretical values of machine output, not the actual resin pressure.
⁴ Plasticizing capacity(GPPS):GB standard, with application of GPPS plasticizing capacity of 3-zone screws.
⁵ Plasticizing capacity(HDPE):Euromap 19, with application of HDPE plasticizing capacity of barrier screws.

This parameter table is based on machine standard configuration;
 We reserve the right to make changes as a result of further technical advances.

MACHINE DIMENSIONS

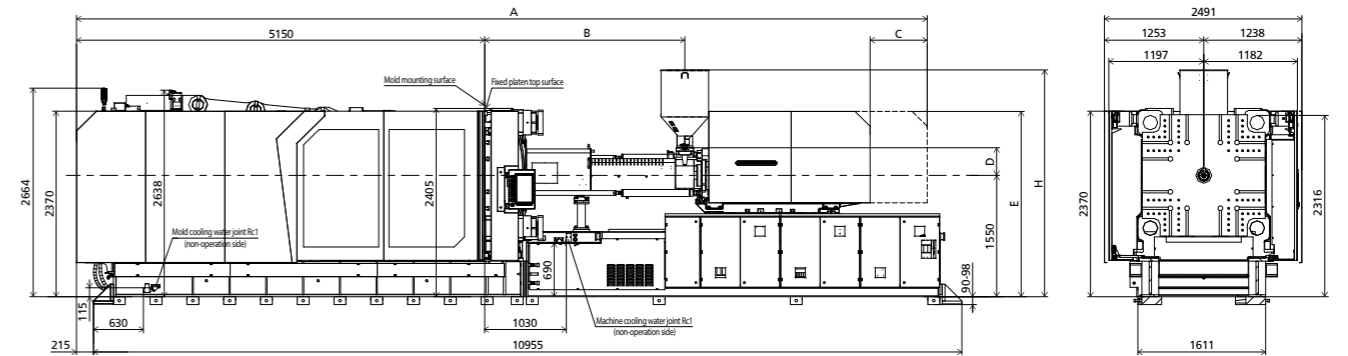

	A	B	C	D	E	F	G	H	I	J	K	L	M	N
2250,2250h	9280	1630	610	327	2201	4XM10 L20	115	2564	225	95	115	67	Ø4	SR15
3350	9549	1841	610	346	2201	4XM12 L25	170	2890	225	100	170	128	Ø4	SR15
5200	10371	2278	720	356	2367	4XM12 L20	170	2884	220	100	170	105	Ø4	SR15
6700	10732	2525	720	354	2367	4XM12 L20	170	2897	232	100	170	115	Ø6	SR20

PLATEN DIMENSIONS

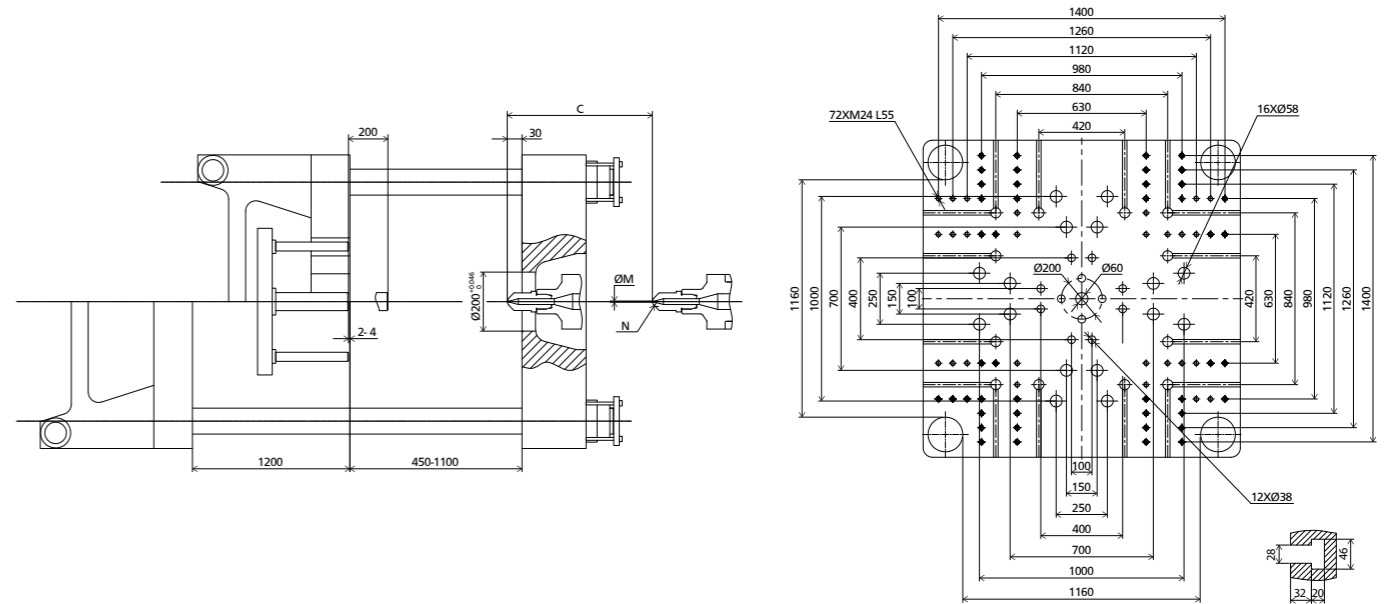

OTHERS DIMENSIONS

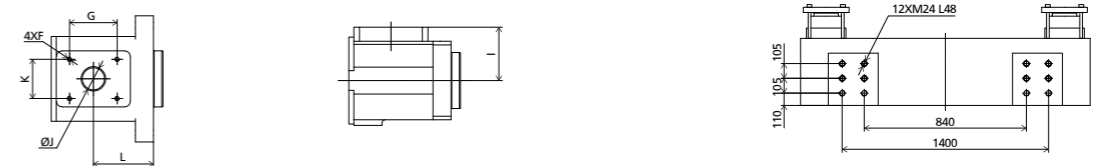

HOPPER MOUNTING DIMENSION

ROBOT TOP VIEW FIXED PLATEN

TECHNICAL DATA ZE10000 V

CLAMPING UNIT														
Clamping force	kN	10000												
Mold opening stroke	mm	1200												
Mold height min.	mm	450												
Mold height max.	mm	1100												
Total daylight max.	mm	2300												
Dist. Between tie-bars (H×V)	mm	1160×1160												
Size of mold platen (H×V)	mm	1590×1590												
Mold dimension min.	mm	770×770												
Ejector stroke	mm	200												
Ejector force	kN	230												
		A	B	C	A	B	C	A	B	C	A	B	C	
Screw diameter	mm	65	70	80	75	80	90	80	90	100	90	100	110	
Screw L/D ratio	L/D	21.5	20	17.5	21.3	20	17.8	24.8	22	19.8	24.4	22	20	
Injection volume (theoretical) ¹	cm ³	1068	1239	1618	1634	1859	2353	2261	2862	3534	2989	3691	4466	
Injection weight (PS) ²	g	972	1127	1472	1487	1692	2141	2058	2605	3216	2720	3359	4064	
Injection pressure ³	MPa	210	180	138	205	180	142	227	180	145	222	180	149	
	bar	2100	1800	1380	2050	1800	1420	2270	1800	1450	2220	1800	1490	
Holding pressure ³	MPa	190	162	124	185	162	128	204	162	131	200	162	133	
	bar	1900	1620	1240	1850	1620	1280	2040	1620	1310	2000	1620	1330	
Screw speed	rpm	240			220			190			170			
Plasticizing rate (GPPS) ⁴	g/s	62	71	88	70	92	105	85	107	131	103	127	150	
Plasticizing rate (HDPE) ⁵	g/s	93	111	132	105	141	165	128	162	200	156	191	228	
Nozzle contact force	kN	85			85			85			85			
INJECTION UNIT		2250			3350			5200			6700			
Injection speed	mm/s	160			160			160			150			
Injection rate (PS)	g/s	463	537	702	617	702	889	702	889	1097	833	1029	1245	
INJECTION UNIT		2250h			-			-			-			
Injection speed	mm/s	250			-			-			-			
Injection rate (PS)	g/s	723	839	1097	-	-	-	-	-	-	-	-	-	
OTHERS	Connection power	kW/A	2250:65/109 2250h:89/150			83/138			98/164			126/211		
	Heating power	kW	36.1			42.6			54.3			75.6		
	Machine dimension	m	11.20×2.49×2.67			11.20×2.49×2.67			11.20×2.49×2.67			11.20×2.49×2.67		
	Machine weight	t	55.10			55.20			56.10			56.26		
	Hopper capacity	l	50			100			100			100		
	Pressure	MPa	21			21			21			21		
	Flow	l/min	248			248			248			248		
Oil tank	l	411			411			411			411			

NOTE: ¹ Shot volume is the theoretical value which equals to cross section area of screw cylinder or barrel plunger × screw stroke.
² Shot weight (PS) is the theoretical value of shot volume melt density of PS. It is not a measured value.
³ Injection & holding pressure are theoretical values of machine output, not the actual resin pressure.
⁴ Plasticizing capacity(GPPS):GB standard, with application of GPPS plasticizing capacity of 3-zone screws.
⁵ Plasticizing capacity(HDPE):Euromap 19, with application of HDPE plasticizing capacity of barrier screws.

This parameter table is based on machine standard configuration;
 We reserve the right to make changes as a result of further technical advances.

MACHINE DIMENSIONS

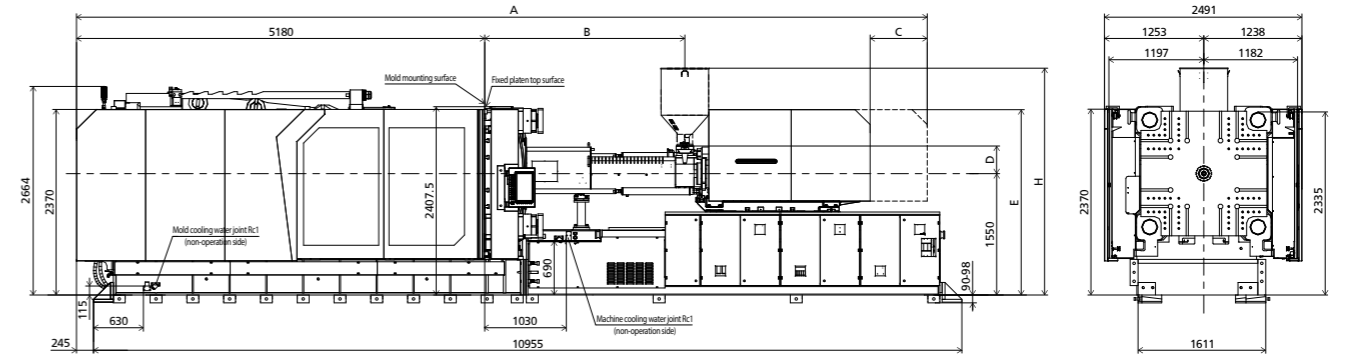

	A	B	C	D	E	F	G	H	I	J	K	L	M	N
2250,2250h	9310	1630	620	327	2201	4XM10 L20	115	2564	225	95	115	67	Ø4	SR15
3350	9579	1841	620	346	2201	4XM12 L25	170	2890	225	100	170	128	Ø4	SR15
5200	10401	2278	720	356	2367	4XM12 L20	170	2884	220	100	170	105	Ø4	SR15
6700	10762	2525	720	354	2367	4XM12 L20	170	2897	232	100	170	115	Ø6	SR20

PLATEN DIMENSIONS

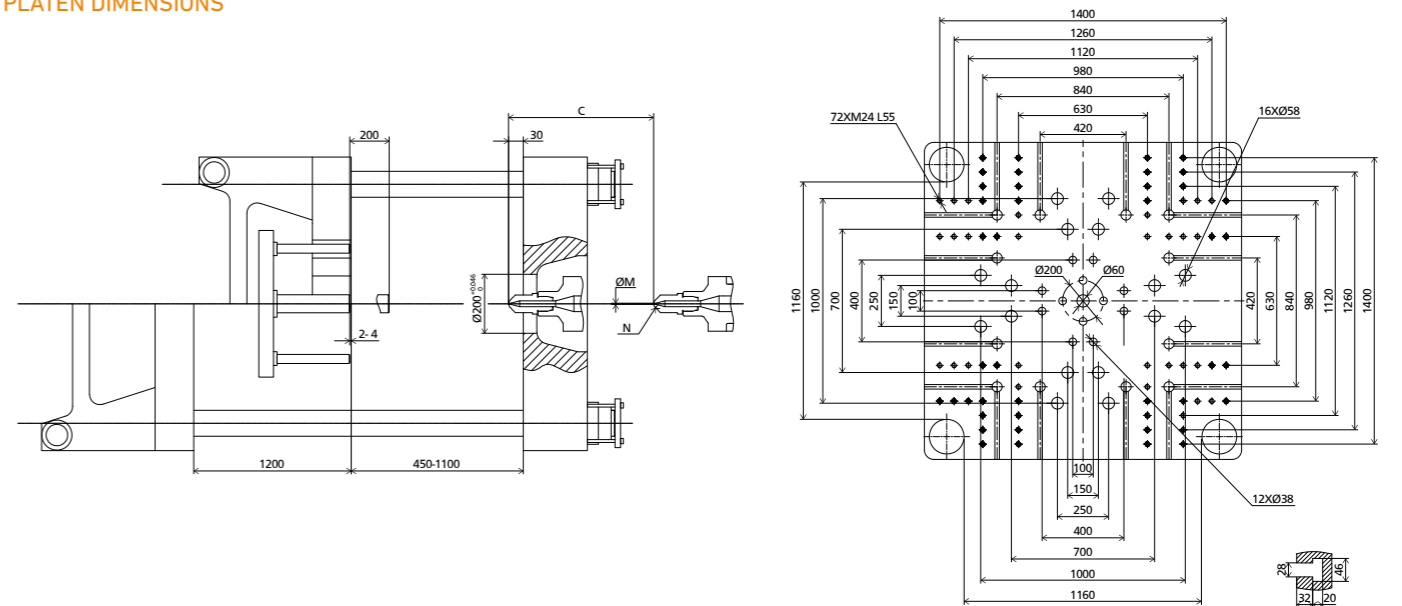

OTHERS DIMENSIONS

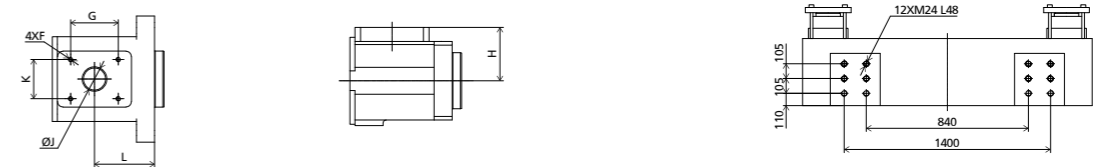

HOPPER MOUNTING DIMENSION

ROBOT TOP VIEW FIXED PLATEN

TECHNICAL DATA ZE11000 V

		CLAMPING UNIT											
		A			B			C			D		
Clamping force	kN	11000											
Mold opening stroke	mm	1300											
Mold height min.	mm	500											
Mold height max.	mm	1200											
Total daylight max.	mm	2500											
Dist. Between tie-bars (H×V)	mm	1320×1320											
Size of mold platen (H×V)	mm	1750×1750											
Mold dimension min.	mm	870×870											
Ejector stroke	mm	200											
Ejector force	kN	230											
		A			B			C			D		
Screw diameter	mm	75	80	90	80	90	100	90	100	110	100	110	120
Screw L/D ratio	L/D	21.3	20	17.8	24.8	22	19.8	24.4	22	20	24.4	22	20.2
Injection volume (theoretical) ¹	cm ³	1634	1859	2353	2261	2862	3534	2989	3691	4466	4005	4846	5767
Injection weight (PS) ²	g	1487	1692	2141	2058	2605	3216	2720	3359	4064	3644	4410	5248
Injection pressure ³	MPa	205	180	142	227	180	145	222	180	149	218	180	151
	bar	2050	1800	1420	2270	1800	1450	2220	1800	1490	2180	1800	1510
Holding pressure ³	MPa	185	162	128	204	162	131	200	162	133	195	162	136
	bar	1850	1620	1280	2040	1620	1310	2000	1620	1330	1950	1620	1360
Screw speed	rpm	220			190			170			155		
Plasticizing rate (GPPS) ⁴	g/s	70	92	105	85	107	131	103	127	150	121	145	168
Plasticizing rate (HDPE) ⁵	g/s	105	141	165	128	162	200	156	191	228	181	217	247
Nozzle contact force	kN	85			85			85			85		
INJECTION UNIT		3350			5200			6700			8700		
Injection speed	mm/s	160			160			150			150		
Injection rate (PS)	g/s	617	702	889	702	889	1097	833	1029	1245	1029	1245	1482
INJECTION UNIT		-			-			-			-		
Injection speed	mm/s	-			-			-			-		
Injection rate (PS)	g/s	-			-			-			-		
OTHERS	Connection power	83/138			98/164			126/211			151/254		
	Heating power	42.6			54.3			75.6			82.8		
	Machine dimension	12.27×2.82×2.76			12.27×2.82×2.76			12.27×2.82×2.76			12.27×2.82×2.76		
	Machine weight	56.50			57.50			57.70			60.90		
	Hopper capacity	100			100			100			200		
	Pressure	21			21			21			21		
	Flow	248			248			248			248		
Oil tank	431			431			431			431			

NOTE: ¹ Shot volume is the theoretical value which equals to cross section area of screw cylinder or barrel plunger × screw stroke.
² Shot weight (PS) is the theoretical value of shot volume melt density of PS. It is not a measured value.
³ Injection & holding pressure are theoretical values of machine output, not the actual resin pressure.
⁴ Plasticizing capacity(GPPS):GB standard, with application of GPPS plasticizing capacity of 3-zone screws.
⁵ Plasticizing capacity(HDPE):Euromap 19, with application of HDPE plasticizing capacity of barrier screws.

This parameter table is based on machine standard configuration;
 We reserve the right to make changes as a result of further technical advances.

MACHINE DIMENSIONS

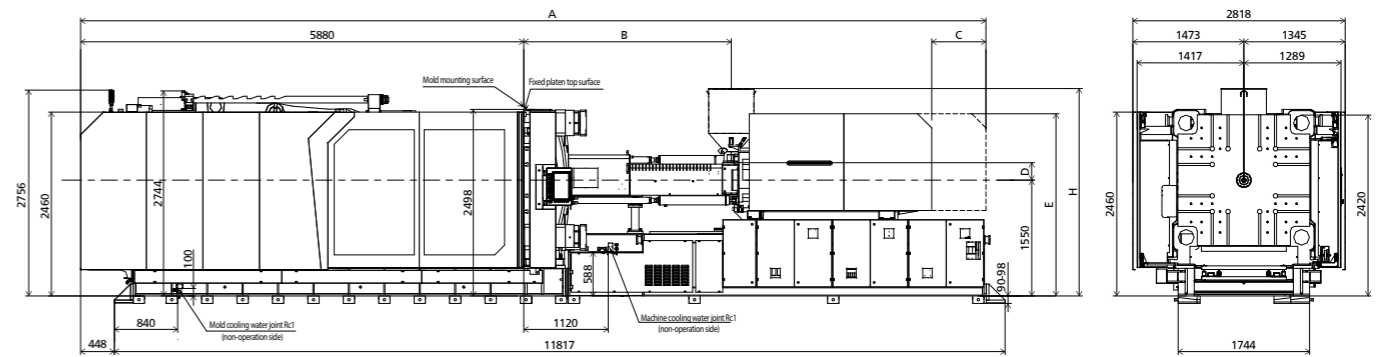

	A	B	C	D	E	F	G	H	I	J	K	L	M	N
3350	10389	1841	720	346	2201	4XM12 L25	170	2890	225	100	170	128	Ø4	SR15
5200	11101	2278	720	356	2367	4XM12 L20	170	2884	220	100	170	105	Ø4	SR15
6700	11462	2525	720	354	2367	4XM12 L20	170	2897	232	100	170	115	Ø6	SR20
8700	12012	2753	720	233	2439	4XM12 L20	170	2776	232	122	170	115	Ø6	SR20

PLATEN DIMENSIONS

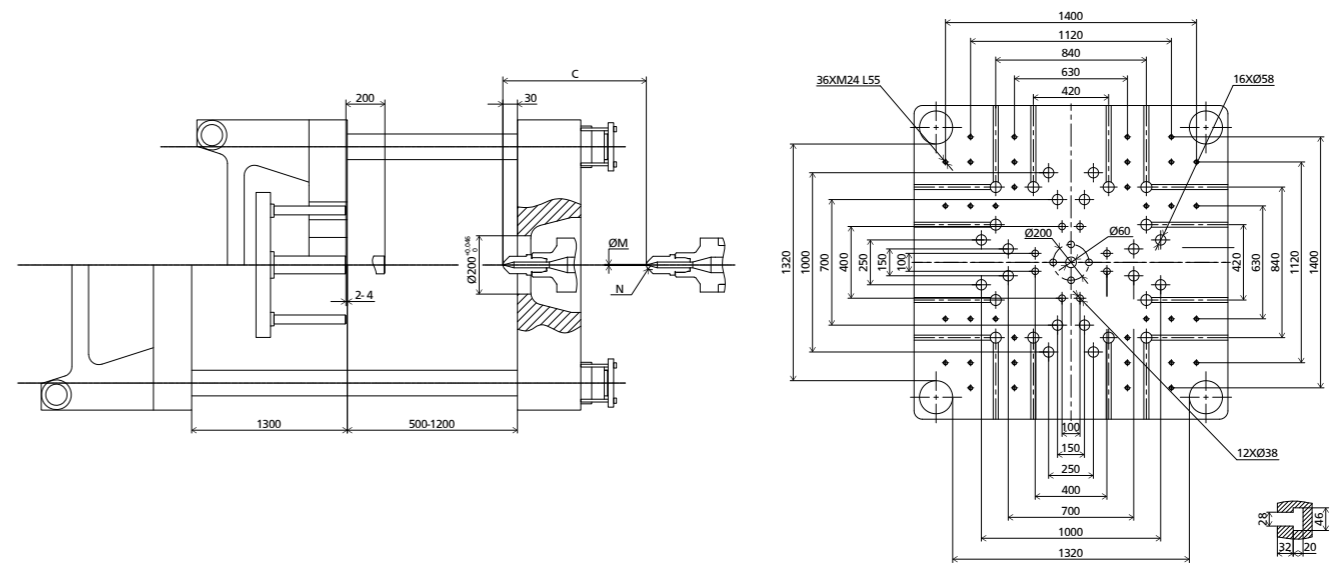

OTHERS DIMENSIONS

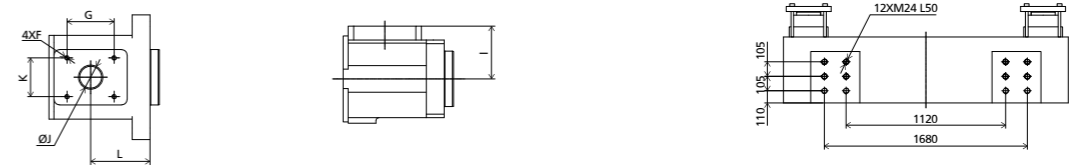

HOPPER MOUNTING DIMENSION

ROBOT TOP VIEW FIXED PLATEN



EUROPEAN VERSION
FIXED PLATEN

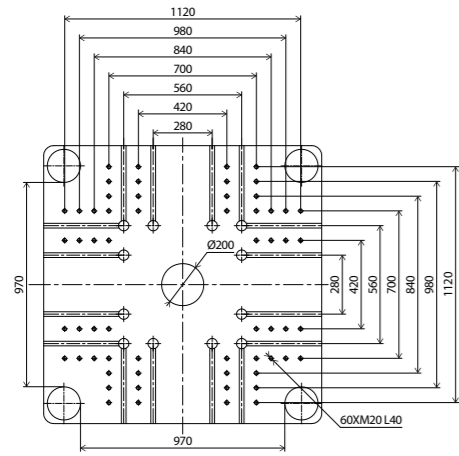

MOVABLE PLATEN

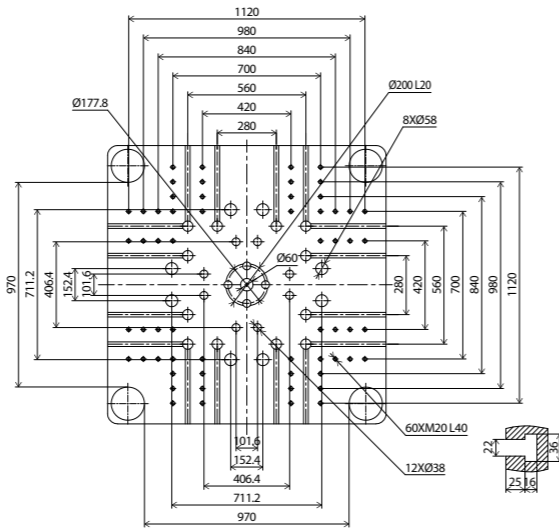

AMERICAN VERSION
FIXED PLATEN

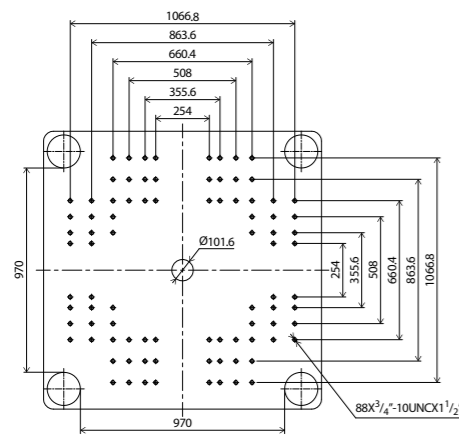

MOVABLE PLATEN

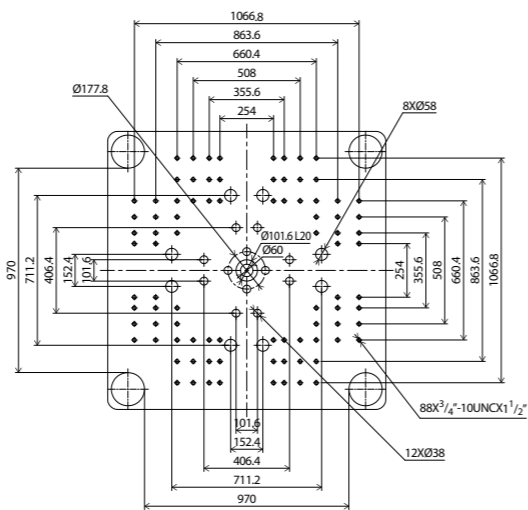

JAPANESE VERSION
FIXED PLATEN

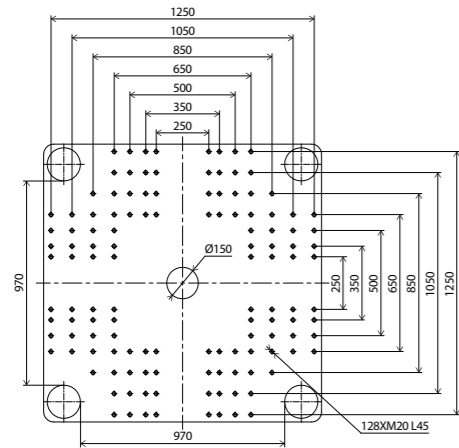

MOVABLE PLATEN

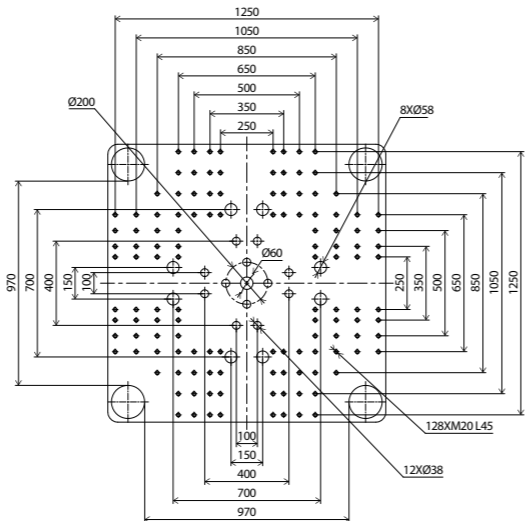

EUROPEAN VERSION
FIXED PLATEN

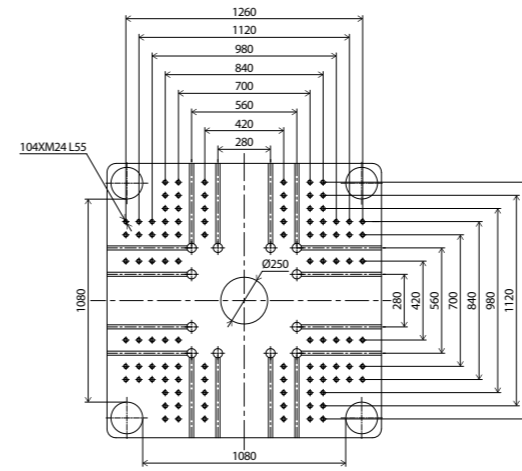

MOVABLE PLATEN

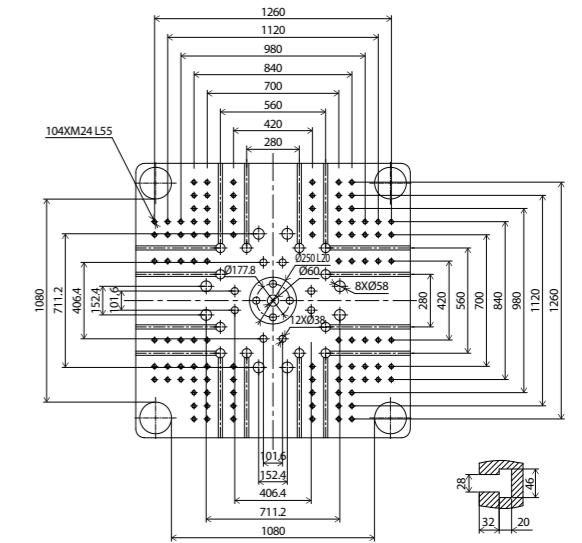

AMERICAN VERSION
FIXED PLATEN

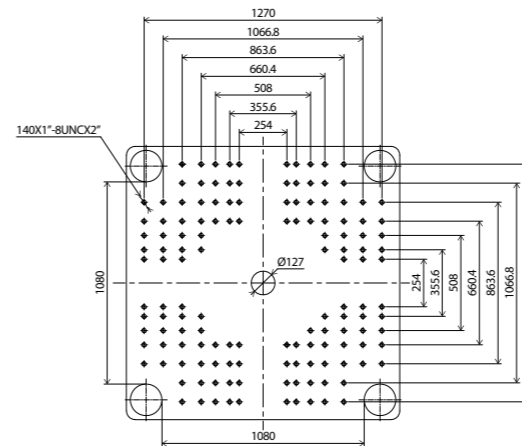

MOVABLE PLATEN

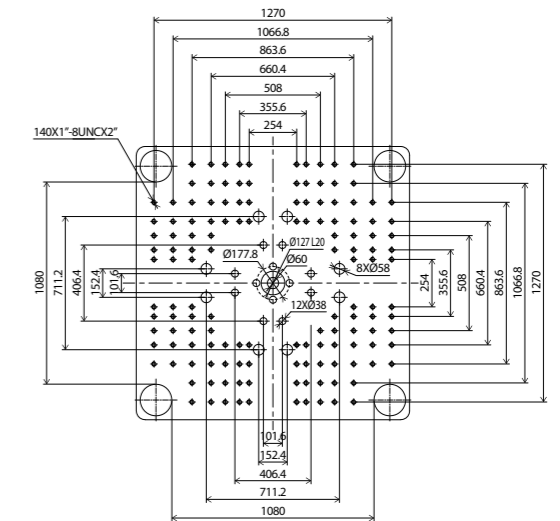

JAPANESE VERSION
FIXED PLATEN

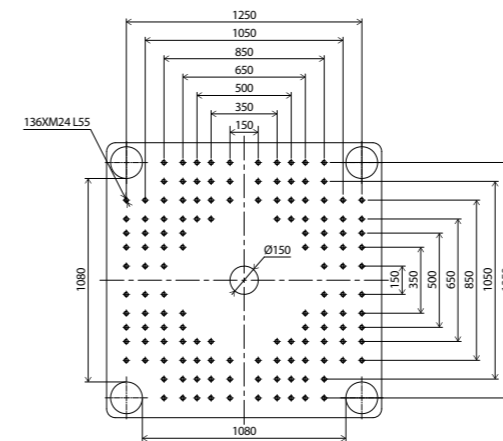

MOVABLE PLATEN

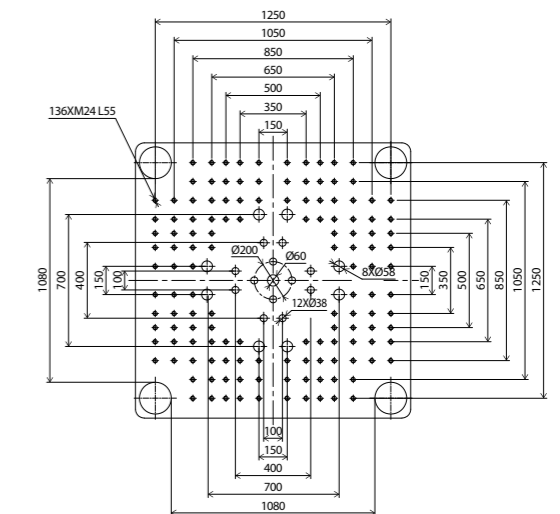

We reserve the right to make changes as a result of further technical advances.

EUROPEAN VERSION
FIXED PLATEN

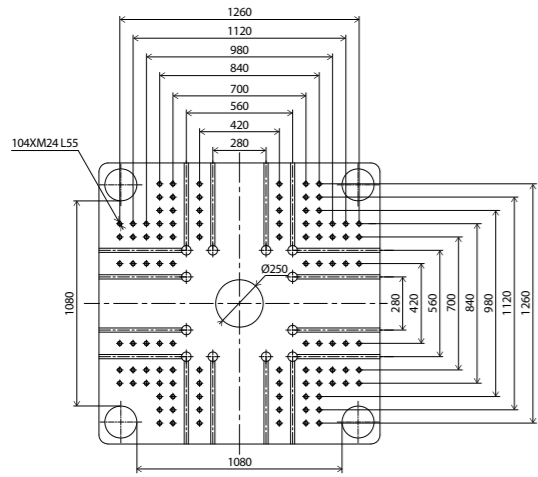

MOVABLE PLATEN

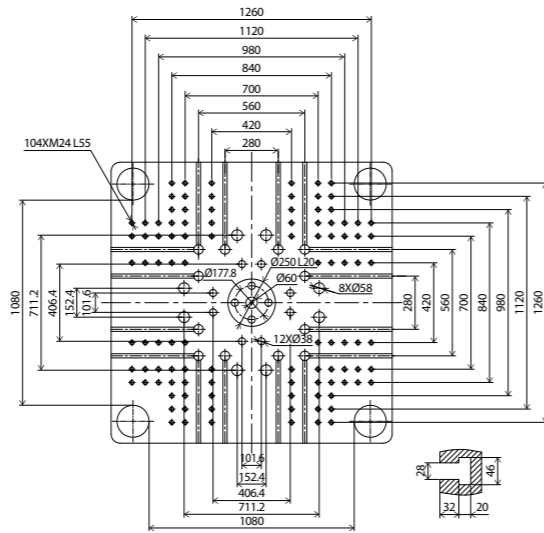

AMERICAN VERSION
FIXED PLATEN

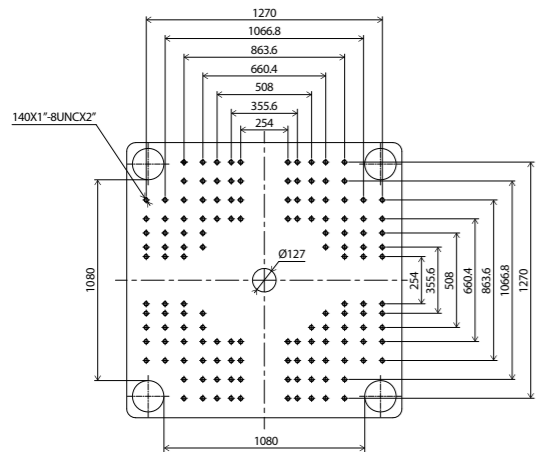

MOVABLE PLATEN

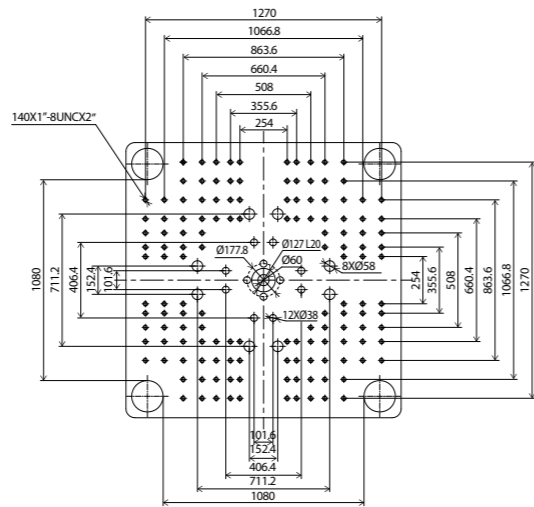

JAPANESE VERSION
FIXED PLATEN

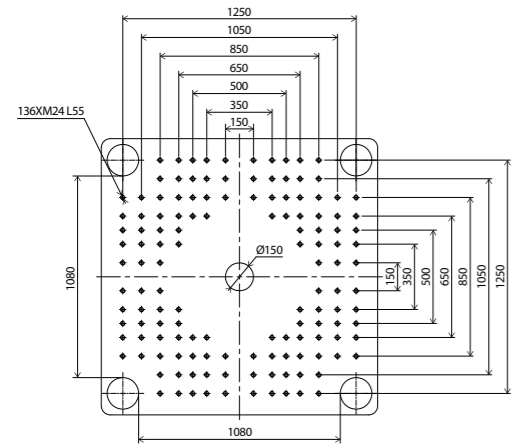

MOVABLE PLATEN

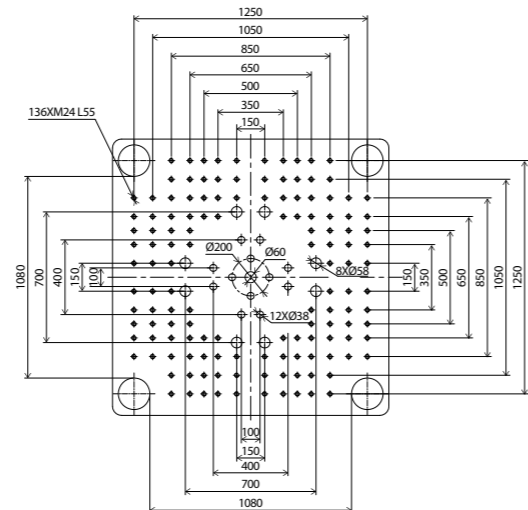

EUROPEAN VERSION
FIXED PLATEN

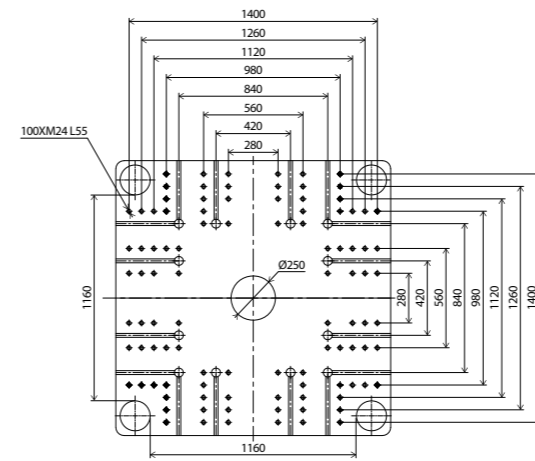

MOVABLE PLATEN

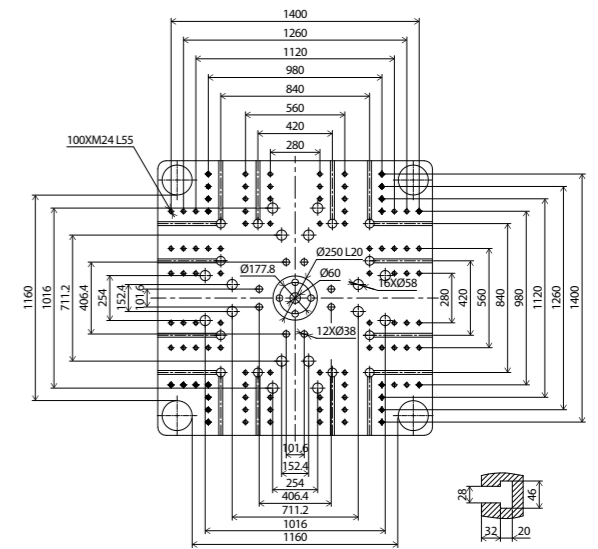

AMERICAN VERSION
FIXED PLATEN

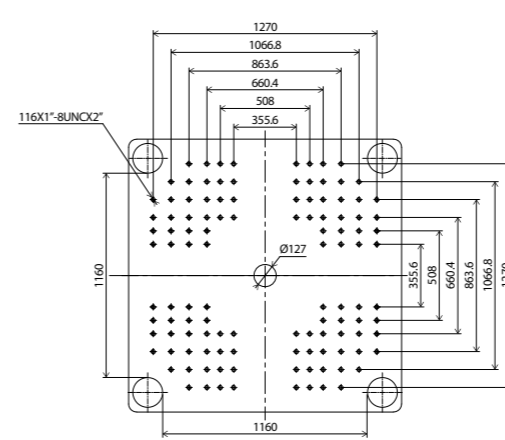

MOVABLE PLATEN

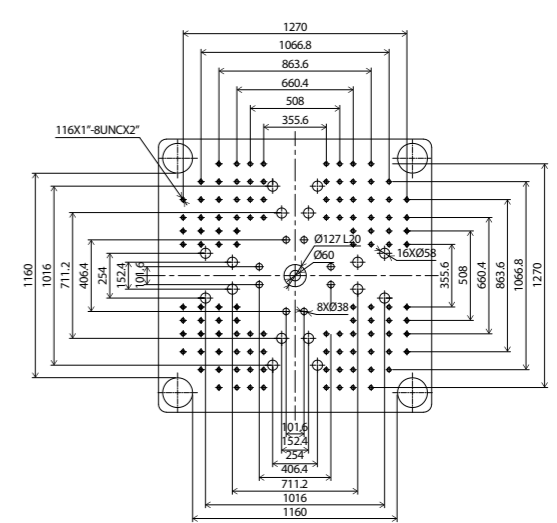

JAPANESE VERSION
FIXED PLATEN

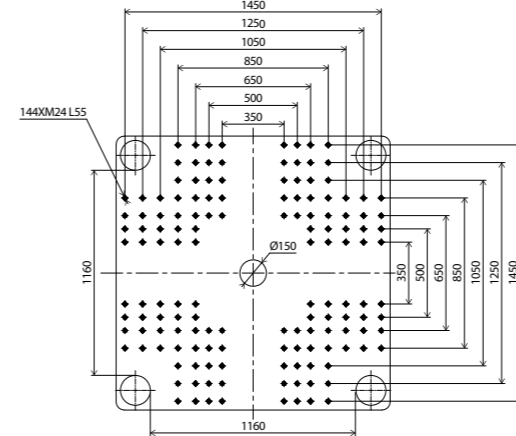

MOVABLE PLATEN

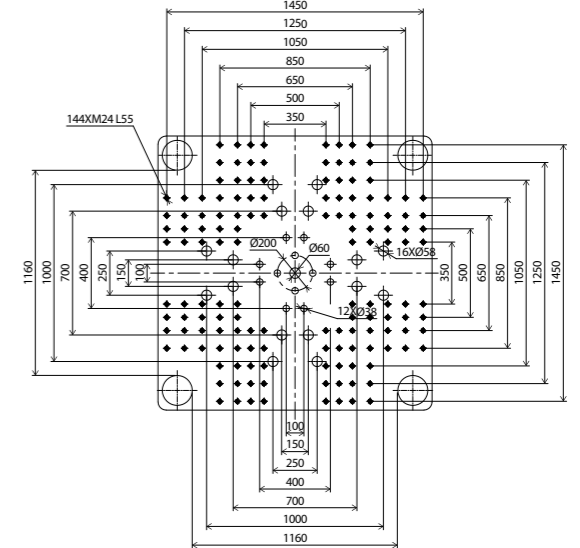

We reserve the right to make changes as a result of further technical advances.

EUROPEAN VERSION
FIXED PLATEN

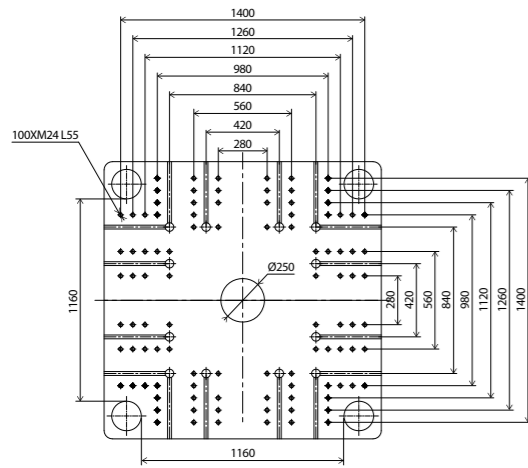

MOVABLE PLATEN

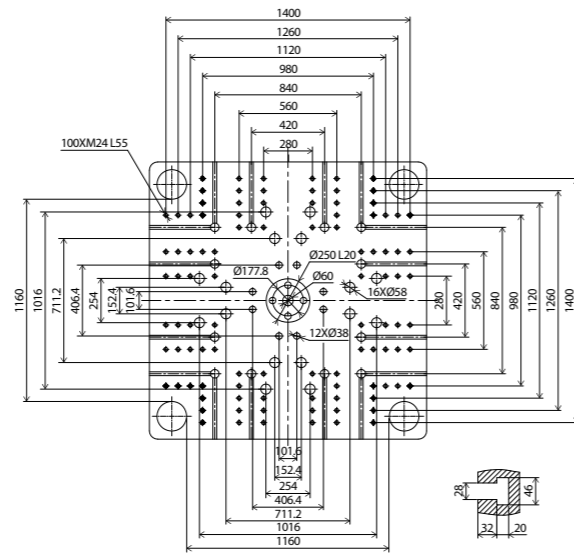

EUROPEAN VERSION
FIXED PLATEN

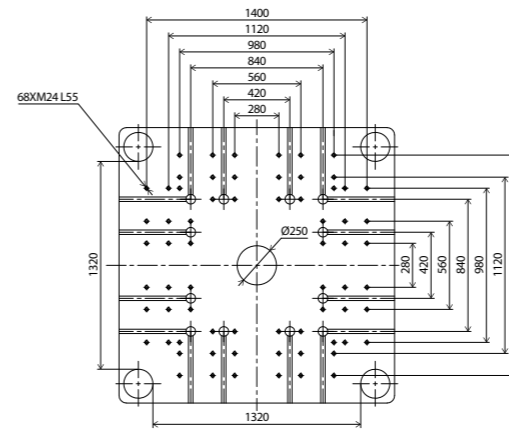

MOVABLE PLATEN

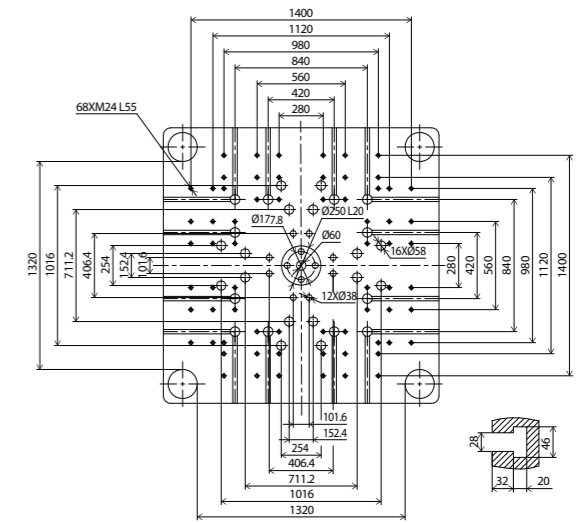

AMERICAN VERSION
FIXED PLATEN

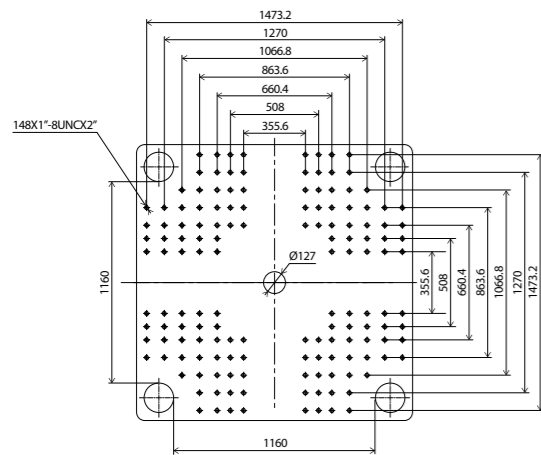

MOVABLE PLATEN

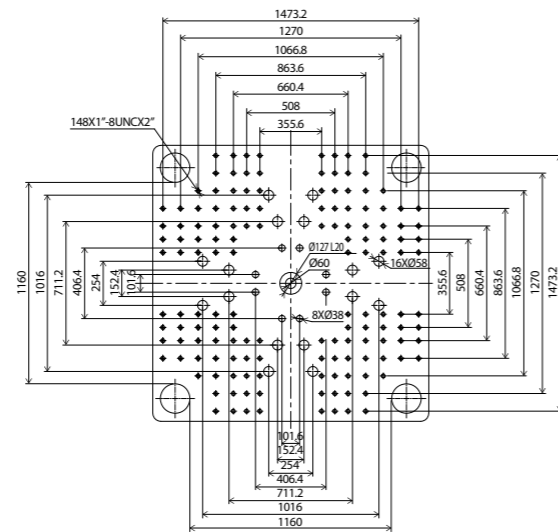

AMERICAN VERSION
FIXED PLATEN

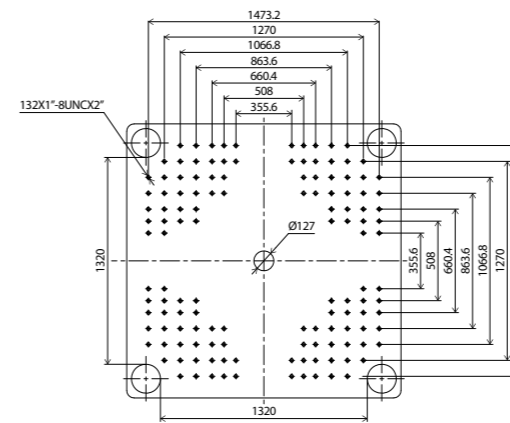

MOVABLE PLATEN

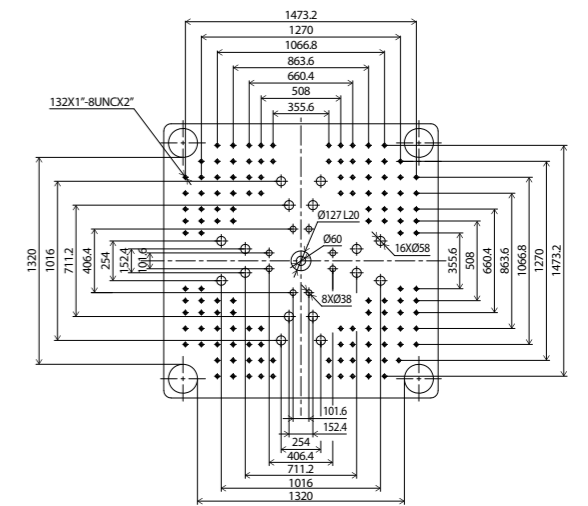

JAPANESE VERSION
FIXED PLATEN

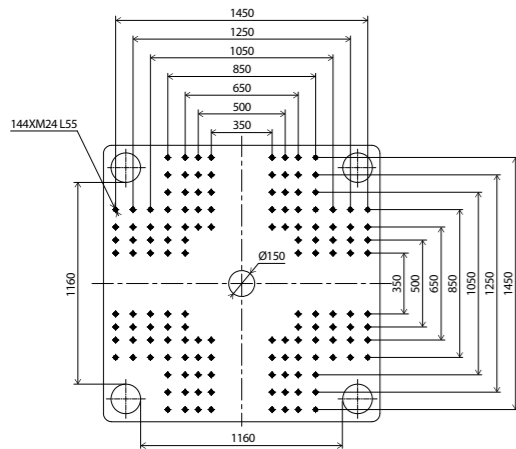

MOVABLE PLATEN

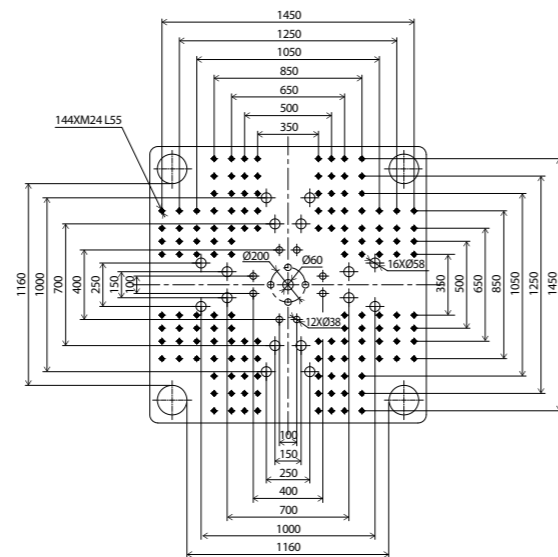

JAPANESE VERSION
FIXED PLATEN

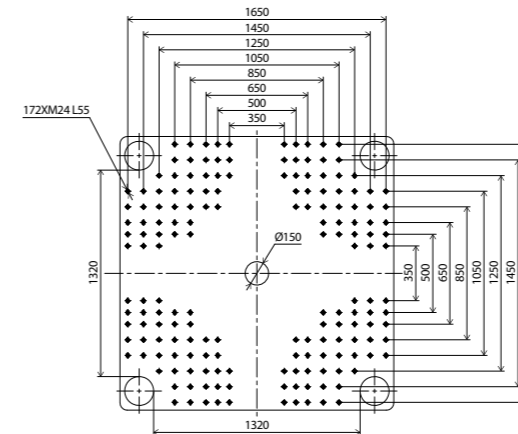

MOVABLE PLATEN

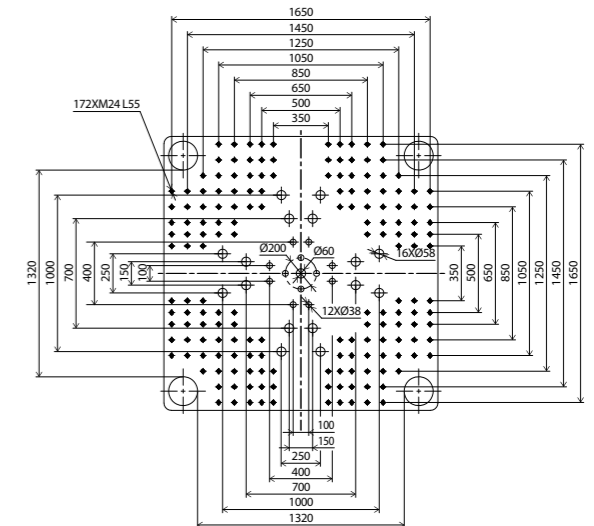

We reserve the right to make changes as a result of further technical advances.

EUROPEAN VERSION
FIXED PLATEN

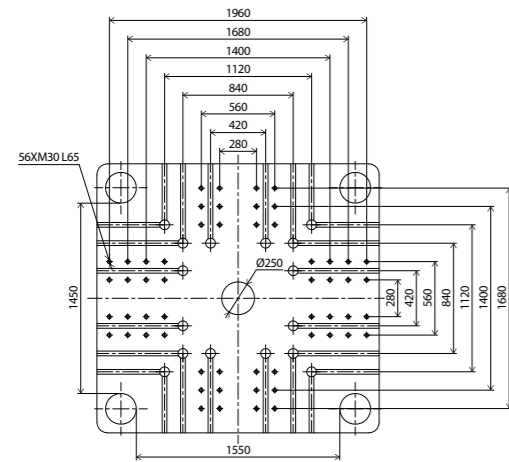

MOVABLE PLATEN

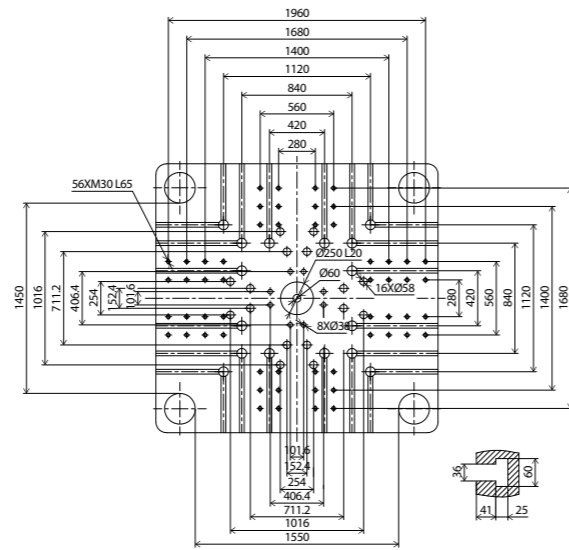

AMERICAN VERSION
FIXED PLATEN

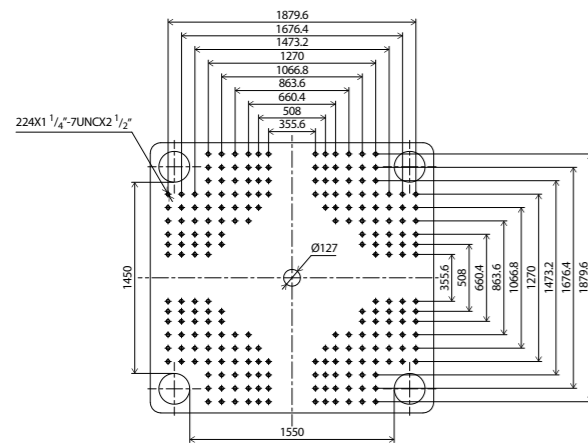

MOVABLE PLATEN

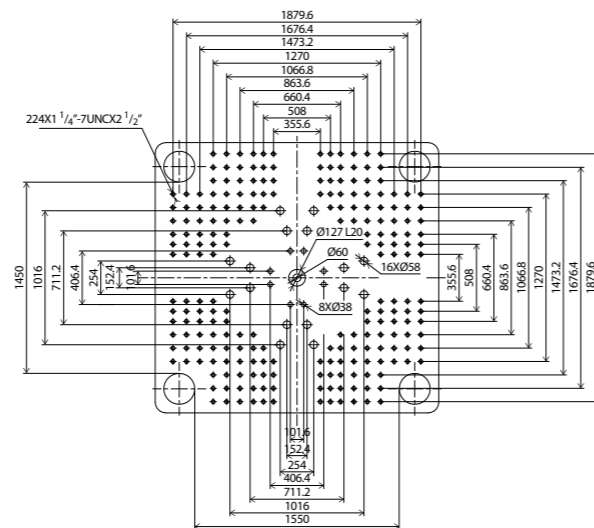

JAPANESE VERSION
FIXED PLATEN

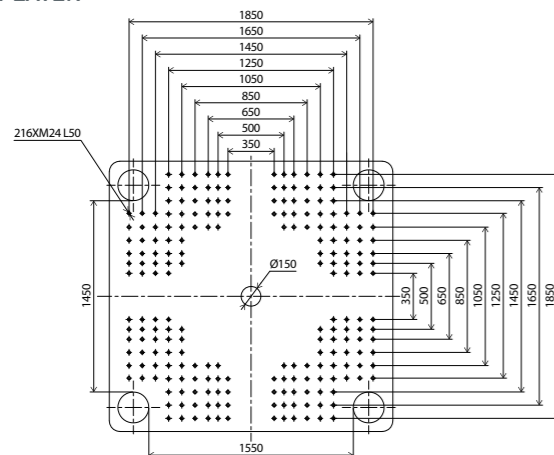

MOVABLE PLATEN

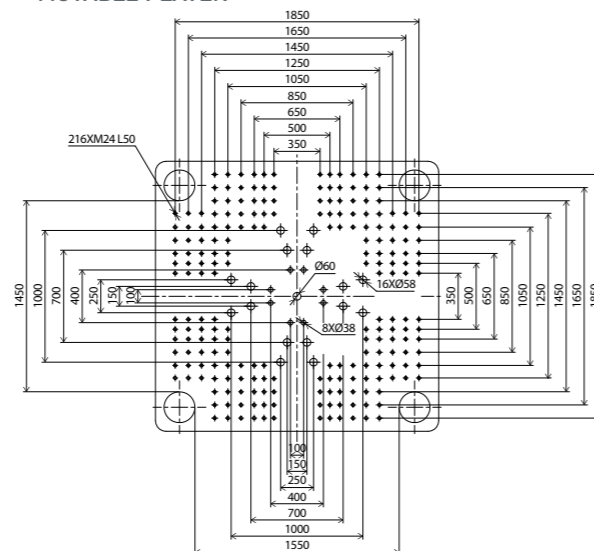

GENERAL EQUIPMENT

- » Basic safety device according to GB/22530
- » ZHAFIR colors: RAL9010, RAL5003
- » Power supply: 380VAC, 3PH+N+PE
- » Sigmatek controller, 15.1 inch touch screen
- » Injection, dosing, platen movement driven independently by servo motor, optical encoder position detection
- » LUBE central lubrication

INJECTION UNIT

- » Abrasion-resistant screw set, general version
- » Open nozzle
- » Barrel heating temperature PID control, SSR
- » Extended nozzle, temperature PID control independently
- » Feeding zone temperature closed-loop control
- » Injection speed 6 steps
- » Speed responding mode adjustable
- » Holding pressure 4 steps
- » Pressure responding mode adjustable
- » V/P switch over methods by position/ time/ pressure combinations
- » Dosing rotation speed 3 steps
- » Back pressure 3 steps
- » HPM over-filling protection function
- » Screw retraction before and/or after dosing
- » Auto purge

CLAMPING UNIT

- » 5-point twin toggle mechanism
- » Center pressing platen
- » Clamping force settable at control panel
- » Automatic mold-height adjustment
- » Platen moving speed 6 steps
- » AI mold protection
- » Clamping force pre-release
- » Ejector speed 3 steps
- » Ejector pressure 3 steps
- » Multi ejection function
- » Ejection parallel to mold opening

FUNCTIONS & CONTROLS

- » Multi-language available (Chinese, German, English, Japanese etc.)
- » Metric/Imperial unit selectable
- » Dosing parallel to mold opening
- » Injection compression
- » Production assistant device function
- » Maintenance alert
- » 5000 cycles process data recording
- » Amendment report
- » Alarm record
- » Quality control function
- » Mold profile data memory (up to 200 sets)
- » 2 USB interface
- » USB printer interface
- » Injection speed & pressure curve
- » 1 free programmable I/O
- » Mold ejector protection interface
- » EUROMAP 12 interface for handling device
- » Auxiliary socket 3PH/380V 32A×1, 16A×2
- » 3 color alarm lamp (red/yellow/green)

OTHERS

- » Tool kit & spare parts package
- » Leveling pads
- » Documents with machine
- » Operating manual

NOTE

1	
2	
3	
4	
5	
6	
7	
8	
9	
10	
1	
2	
3	
4	
5	
6	
7	
8	
9	
10	
1	
2	
3	
4	
5	
6	
7	
8	
9	
10	
1	
2	
3	
4	
5	
6	
7	
8	
9	
10	